

PD SIGN PLAN  
ORLANDO HEALTH DOWNTOWN CAMPUS WAYFINDING



Prepared for:  
Orlando Health

Prepared by:  
AECOM



**PD SIGN PLAN  
ORLANDO HEALTH DOWNTOWN CAMPUS WAYFINDING**

*Prepared for:*  
Orlando Health

*Prepared by:*  
AECOM

August 2012

# TABLE OF CONTENTS

1	Introduction	
1	Coordination with the City of Orlando	
2	General Conditions	
2	Sign Types	
	– Sign Palette	
	– Table of Sign Standards	
	– Detailed Sign Specifications	
54	Sign Locations	
64	Documentation of Other Approved Signs	

## Introduction

Orlando Health is an existing Planned Development within the City of Orlando. As a major center for hospital and medical related uses for the region, Orlando Health seeks to provide a consistent, logical, and effective wayfinding system for the thousands of patients and employees who travel to and from the downtown campus every day. The following document represents the Master Sign Plan for the Orlando Health PD. The original Sign Plan was adopted as an exhibit to the Amended and Restated PD of 1998 and further amended in 2004. The record of the 2004 Plan was lost, necessitating a replacement version, approved by Planning Official Determination in 2007. Several minor amendments have been made since the replacement plan was approved to add specific new signage.

In 2011, Orlando Health underwent an institute-wide rebranding, including a new corporate name, logo, color scheme, etc. Along with this rebranding came renewed interest in the downtown campus' signage system. By March 2012, a comprehensive new wayfinding plan was produced to completely overhaul campus signage. Major changes from the previously adopted sign plan include:

- A revamped sign palette, with new designs for all campus signs, consistent with the updated brand;
- New on-site sign locations;
- The addition of off-site signage through an Encroachment Agreement with the City.

Though the new plan was developed essentially from scratch, some sign locations are consistent between the previously adopted plan and this plan.

## Coordination with City of Orlando

As an exhibit to the Orlando Health PD, this Sign Plan describes approvals for both on-site signs (signs on Orlando Health PD property) and off-site signs (signs in the ROW or on property not owned by Orlando Health) within and adjacent to the Orlando Health downtown Campus. The Hospital has had extensive coordination with and cooperation from the City of Orlando regarding the development of campus wayfinding. This continued working relationship will help facilitate a logical, cohesive, and coordinated vehicular and pedestrian environment as Orlando Health continues to expand its medical facilities and services for Central Florida.

## Amendment Process

From time to time, as conditions on the campus change, it will be necessary to amend the approved Sign Plan. Amendments to the Sign Plan are accomplished through Planning Official Determination (POD). Changes requiring a POD include:

- Increasing the number of approved signs;
- Significant relocation of an existing sign;
- Adding to or changing the approved sign palette;

*Note: Adding or moving signs within the ROW must also be reviewed according to the conditions of the Encroachment Agreement.*

Changes not requiring a POD include:

- Replacing message text;
- Maintenance;
- Reasonable adjustments to the location of an existing sign within the same property;



## General Conditions

The following general conditions shall apply to signs within the Orlando Health Downtown Campus:

- Flexibility of Location (on-site signs) – all on-site sign locations shown on the maps included with this document are approximate and do not describe exact locations. Actual sign positions will be subject to conditions on the ground, as presented in the permitting process.
- Offsite Sign Locations – all off-site signs located within City ROW must be approved as part of an Encroachment Agreement with the City and are subject to permitting. Approval for the signs includes a joint site assessment between City Staff and the Hospital to determine appropriate locations. Signs on properties not owned by Orlando Health are subject to signage easements with the appropriate property owners.
- Lighting – unless specifically stated, all signs may be internally or externally lit, in accordance with City Code and as detailed in the permitting process. Where appropriate, signs may be designed to utilize solar power, with PV panels and battery storage incorporated into the design of the sign.
- Maintenance – routine maintenance carried out on signs and the updating of message text shall not require a permit or an amendment to this Sign Plan.
- Street Signs – the upgrading of street signs is permitted within MUTCD standards and with the coordination of the City's Transportation Department.
- High Rise Signs – high rise signs are governed by the Orlando Health PD Ordinance and Section 64.246 of the City of Orlando Code of Ordinances.

- Building Address Identifiers – Each building on campus is allowed one (1) wall or canopy-mounted Building Address Identifier not to exceed 9" in height.

- Internal Signs – Signs that are internal to buildings, parking garages, parking lots, plazas, and pedestrian walkways that do not otherwise address the public ROW shall not be governed by this PD Sign Plan.

## Sign Types

The following pages outline the design and dimensions of the range of sign types approved within this Sign Plan.

- The Sign Palette illustrates the standard sign types that are used throughout the OH Campus area.
- The Table of Sign Standards provides for the maximum dimensions and number signs for each sign type.
- The sign specification sheets show the details and typical dimensions of standard sign types.



A – Major Vehicular Gateway



B – Minor Vehicular Gateway

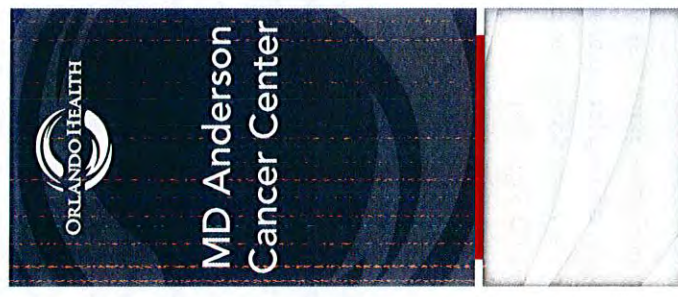

C – Hospital ID



D – Building ID





HEART INSTITUTE

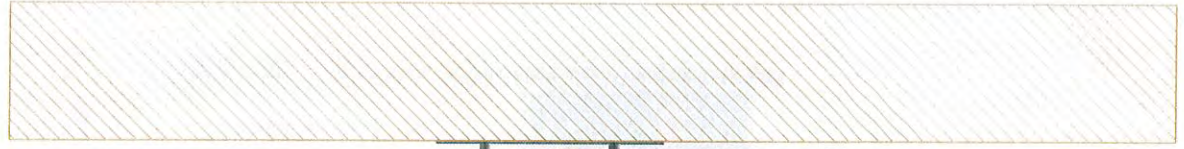

HEART INSTITUTE

↑  
Patient  
Drop-off



PUBLIC  
PARKING  
→

Best Parking For  
ORMC  
MD Anderson  
Heart Institute



E – Parking Directional      F – Parking Building ID      G-1 – Heart Institute Directional      G-2 – Heart Institute ID



H-1 – City of Orlando Vehicular Directional 25+ mph



H-2 – City of Orlando Vehicular Directional < 25 mph



I, J – Vehicular Directional with Emergency Blade (Solar & Standard)



K, L – Vehicular Directional (Solar & Standard)

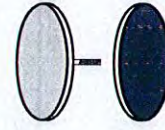
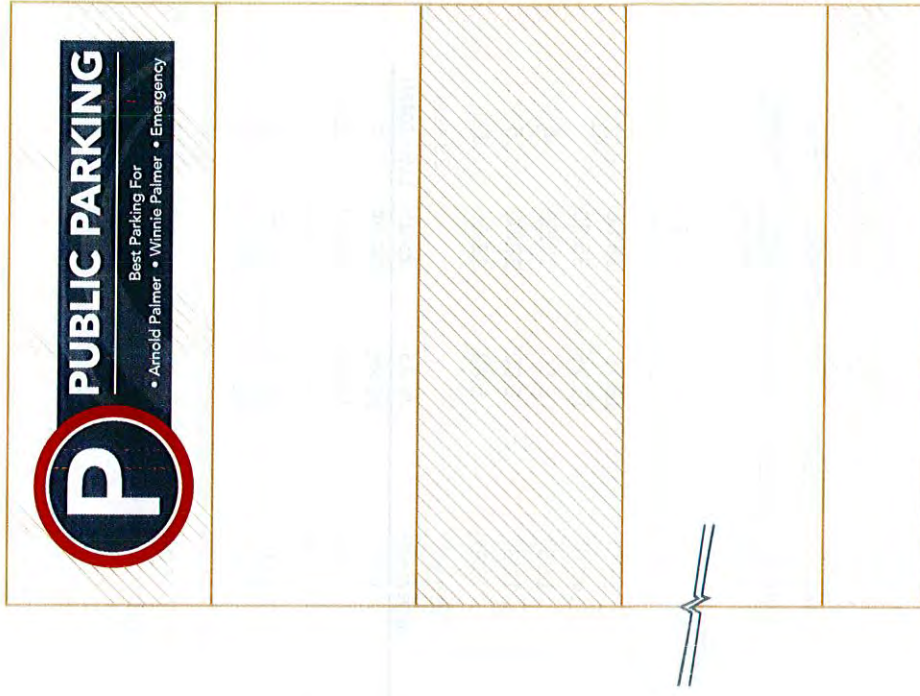

M – Pedestrian Directional  
 N – Pedestrian Kiosk Map  
 O – Sidewalk Directional Medallions



R – B-Deck Garage ID

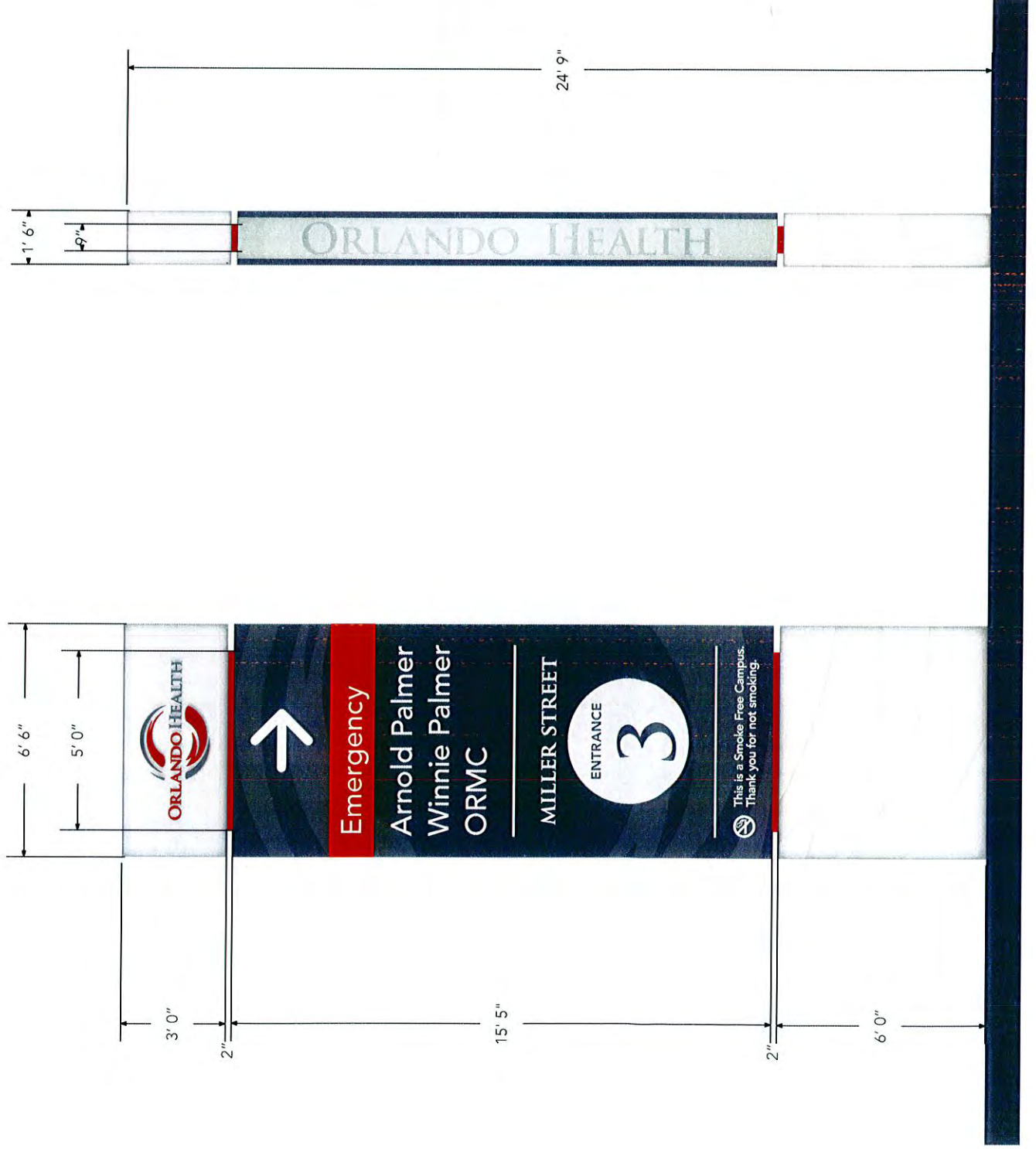

Table of Sign Standards

Sign Type Name	Sign Type Code	Description	Max Height	Max Area (sq ft per face)	Max Area (sq ft total)	Max Number
Major Vehicular Gateway	A	Monument	22'9"	160.37	394.48	1
Minor Vehicular Gateway	B	Monument	18'10"	108.15	272.42	3
City of Orlando Vehicular Directional (1)	H-1	Pole Mounted		31.71	63.88	11
City of Orlando Vehicular Directional (2)	H-2	Pole Mounted		20.11	40.62	2
Vehicular Directional (solar option)	I,J,K,L	Pole Mounted	13'6"	16.75	35.80	41
Pedestrian Directional	M	Pole Mounted	14'10"	16.75	35.80	4
Parking Directional	E	Pole Mounted	11'5"	8.50	17.50	5
Pedestrian Kiosk Map	N	Pole Mounted	11'3"	6.00	12.00	12
			6'3"	5.83	11.66	
Pedestrian Medallions	O	Imbedded in Sidewalk	Flush w/ sidewalk	28.25	28.25	29 sets (167 total)
Hospital ID	C	Monument	15'0"	89.81	196.98	5
Building ID	D	Monument	5'0"	20.00	42.50	23
Parking Garage ID + Directional	F	Wall Mounted - marquee	12' 0"	45.5	103	1
Parking Garage ID	R	Wall Mounted	56'0"	29.75	68	1
Institute ID	G	Wall Mounted - marquee	15'9"	86.56	190.92	1
Other Identification	"OI"	Varies	Approved on an individual basis.			4
Wall Mounted ID	"WBI"	Wall Mounted	Approved on an individual basis.			15
High Rise	"HR"	Wall Mounted	Subject to the OH PD and Section 64.246 of Orlando Code			



 <p><b>Orlando Health PD Sign Plan</b></p> <p><b>Sign A — Major Vehicular Gateway</b></p>	
<p><b>Scale:</b> 1/4" = 1'</p> <p>Note: Drawing scale shown on plans is accurate for full size plans only. AECOM is not responsible for scale discrepancies caused by reduced size plans.</p>	<p><b>Description:</b> Major Vehicular Gateway – Internally Lit</p>
<p><b>Original Issue Date:</b> 2012.07.30</p>	
<p><b>Contact:</b> Environmental Graphics/Wayfinding AECOM 407-843-6552 150 N Orange Avenue, Suite 200 Orlando, Florida 32801</p>	
<p>Typical Height = 24' 9" Typical Area per face = 160.37 sq. ft. Typical Area per side = 36.87 sq. ft. Typical Width = 6' 6" Typical Depth = 1' 6"</p>	
<p>Prepared By:</p> 	



# MATERIALS

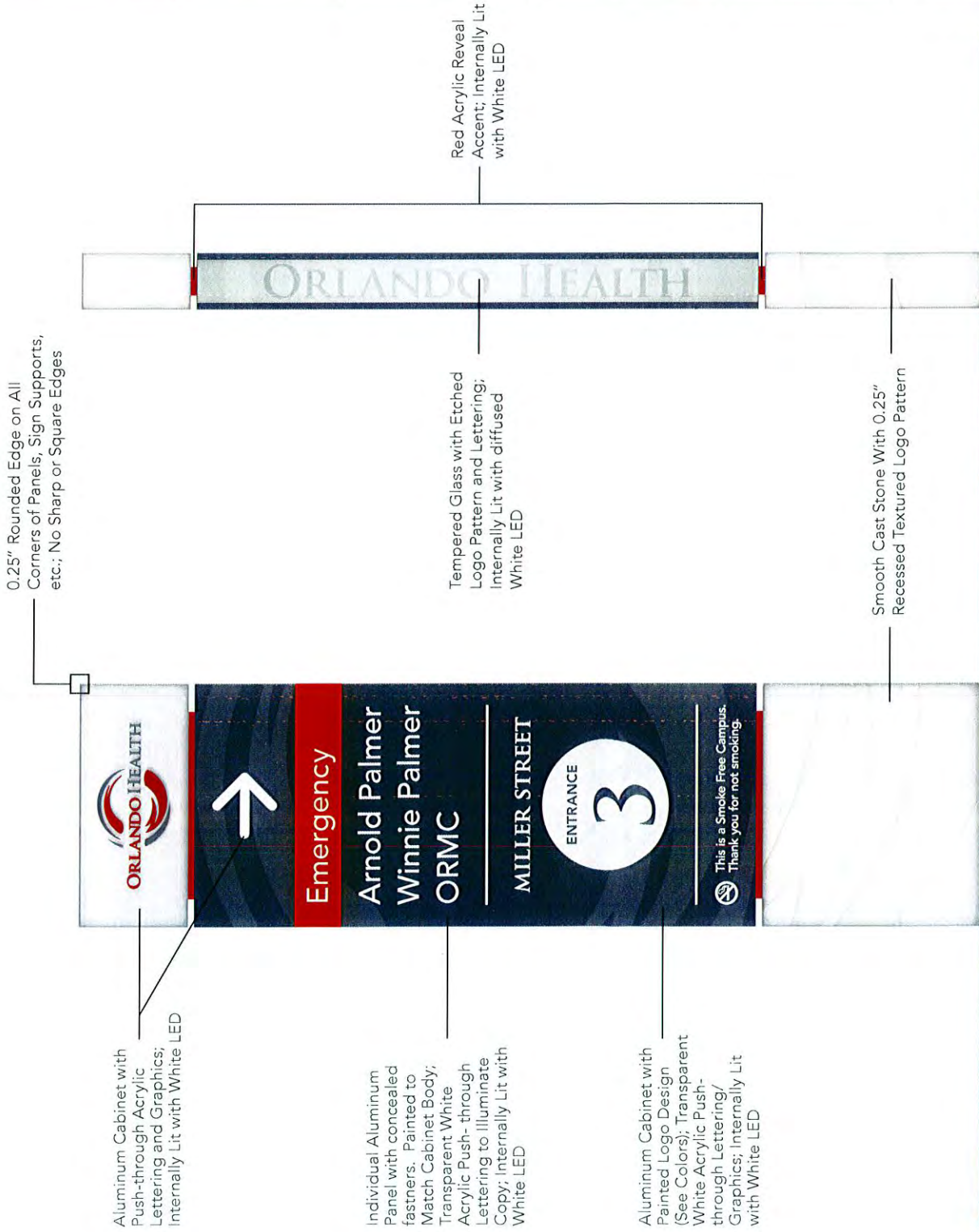

0.25" Rounded Edge on All Corners of Panels, Sign Supports, etc.; No Sharp or Square Edges

Aluminum Cabinet with Push-through Acrylic Lettering and Graphics; Internally Lit with White LED

Individual Aluminum Panel with concealed fasteners. Painted to Match Cabinet Body; Transparent White Acrylic Push-through Lettering to illuminate Copy; Internally Lit with White LED

Aluminum Cabinet with Painted Logo Design (See Colors); Transparent White Acrylic Push-through Lettering/ Graphics; Internally Lit with White LED

Tempered Glass with Etched Logo Pattern and Lettering; Internally Lit with diffused White LED

Red Acrylic Reveal Accent; Internally Lit with White LED

Smooth Cast Stone With 0.25" Recessed Textured Logo Pattern

Scale: 1/4" = 1'

Note: Drawing scale shown on plans is accurate for full size plans only. AECOM is not responsible for scale discrepancies caused by reduced size plans.

Description:  
Major Vehicular Gateway  
- Internally Lit

Original Issue Date: 2012.07.30

Contact:  
Environmental Graphics/Wayfinding  
AECOM  
407-843-6552  
150 N Orange Avenue, Suite 200  
Orlando, Florida 32801

Typical Height = 24' 9"  
Typical Area per face = 160.37 sq. ft.  
Typical Area per side = 36.87 sq. ft.  
Typical Width = 6' 6"  
Typical Depth = 1' 6"

Prepared By:

**AECOM**

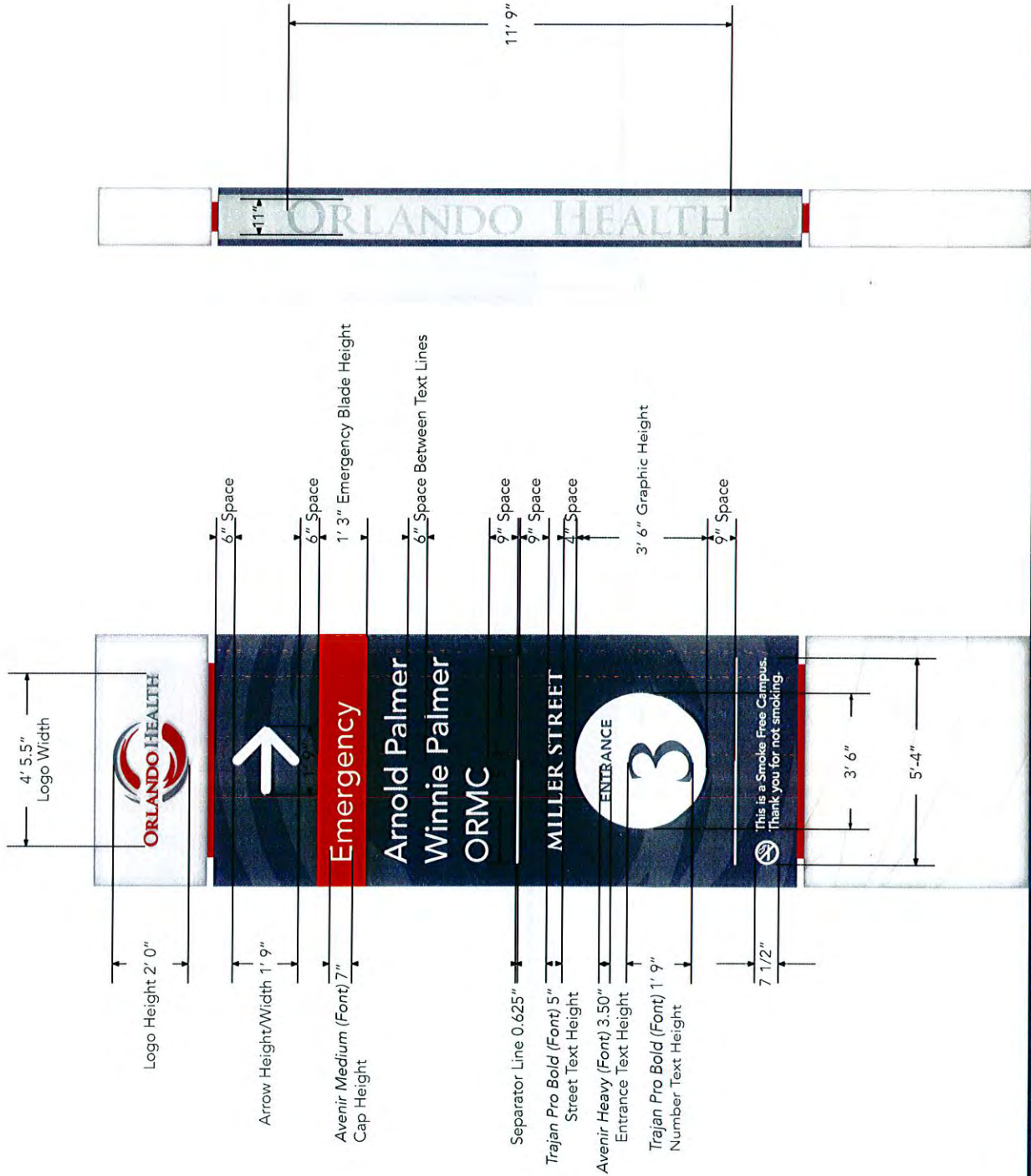

Orlando Health  
PD Sign Plan  
Sign A —  
Major Vehicular  
Gateway

Scale: 1/4" = 1'

Note: Drawing scale shown on plans is accurate for full size plans only. AECOM is not responsible for scale discrepancies caused by reduced size plans.

Description:  
Major Vehicular Gateway  
– Internally Lit

Original Issue Date: 2012.07.30

Contact:  
Environmental Graphics/Wayfinding  
AECOM  
407-843-6552  
150 N Orange Avenue, Suite 200  
Orlando, Florida 32801

Typical Height = 24' 9"  
Typical Area per face = 160.37 sq. ft.  
Typical Area per side = 36.87 sq. ft.  
Typical Width = 6' 6"  
Typical Depth = 1' 6"

Prepared By:





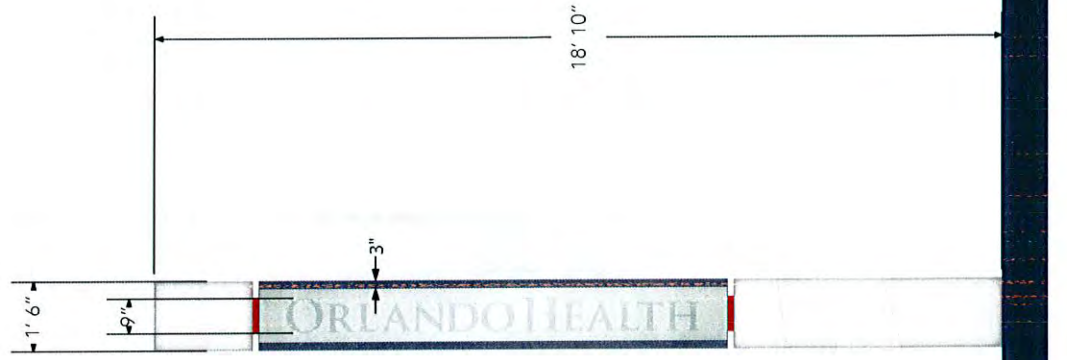
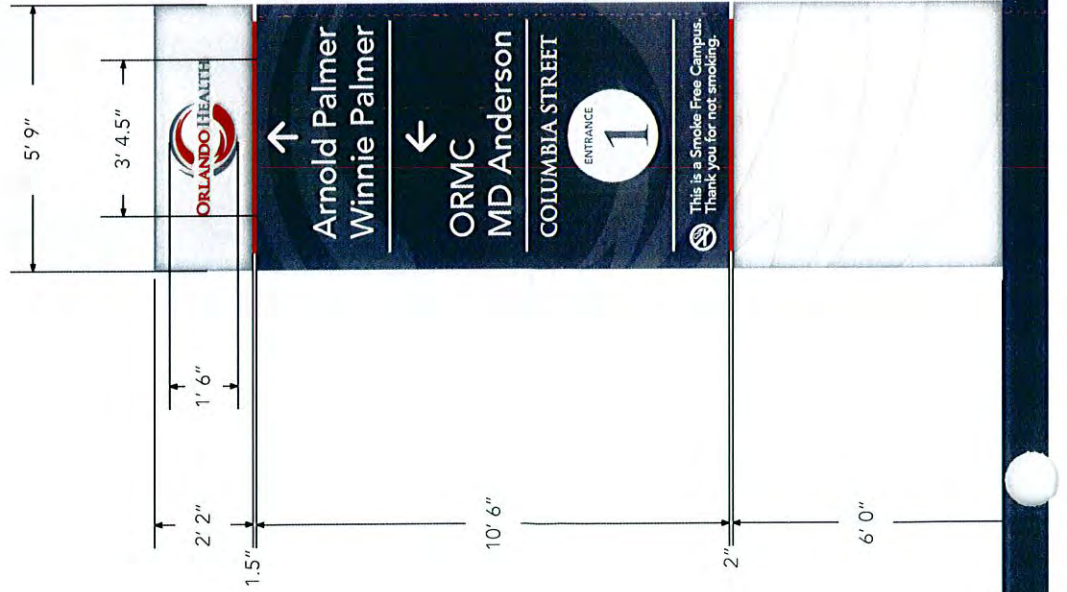

# DIMENSIONS

Top View



	
<b>Orlando Health PD Sign Plan</b>	
<b>Sign B — Minor Vehicular Gateway</b>	
<b>Scale: 1/4" = 1'</b>	Note: Drawing scale shown on plans is accurate for full size plans only. AECOM is not responsible for scale discrepancies caused by reduced size plans.
<b>Description:</b> Minor Vehicular Gateway – Internally Lit	
<b>Original Issue Date:</b> 2012.07.30	
<b>Contact:</b> Environmental Graphics/Wayfinding AECOM 407-843-6552 150 N Orange Avenue, Suite 200 Orlando, Florida 32801	
<b>Typical Height = 18' 10"</b> <b>Typical Area per face = 108.15 sq. ft</b> <b>Typical Area per side = 28.06 sq. ft</b> <b>Typical Width = 5' 9"</b> <b>Typical Depth = 1' 6"</b>	
Prepared By:	
	





Orlando Health  
PD Sign Plan  
Sign B —  
Minor Vehicular  
Gateway

Scale: 1/4" = 1'

Note: Drawing scale shown on plans is accurate for full size plans only. AECOM is not responsible for scale discrepancies caused by reduced size plans.

Description:  
Minor Vehicular Gateway  
– Internally Lit

Original Issue Date: 2012.07.30

Contact:  
Environmental Graphics/Wayfinding  
AECOM  
407-843-6552  
150 N Orange Avenue, Suite 200  
Orlando, Florida 32801

Typical Height = 18' 10"  
Typical Area per face = 108.15 sq. ft  
Typical Area per side = 28.06 sq. ft  
Typical Width = 5' 9"  
Typical Depth = 1' 6"

Prepared By:

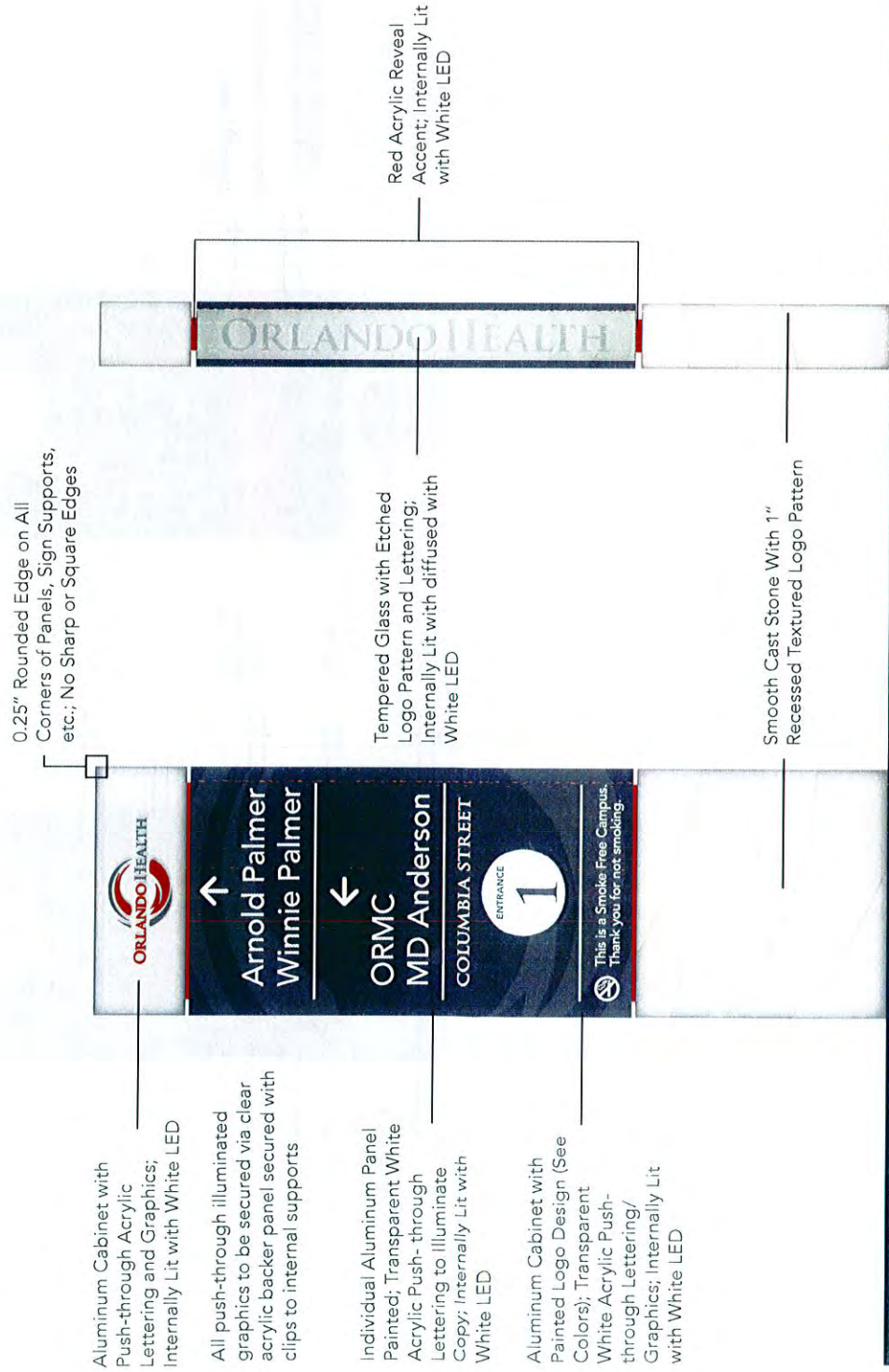



Orlando Health  
PD Sign Plan

Sign B —  
Minor Vehicular  
Gateway

Scale: 1/4" = 1'

Note: Drawing scale shown on plans is accurate for full size plans only. AECOM is not responsible for scale discrepancies caused by reduced size plans.

Description:  
Minor Vehicular Gateway  
– Internally Lit

Original Issue Date: 2012.07.30

Contact:  
Environmental Graphics/Wayfinding  
AECOM  
407-843-6552  
150 N Orange Avenue, Suite 200  
Orlando, Florida 32801

Typical Height = 18' 10"  
Typical Area per face = 108.15 sq. ft  
Typical Area per side = 28.06 sq. ft  
Typical Width = 5' 9"  
Typical Depth = 1' 6"

Prepared By:



Sample Front

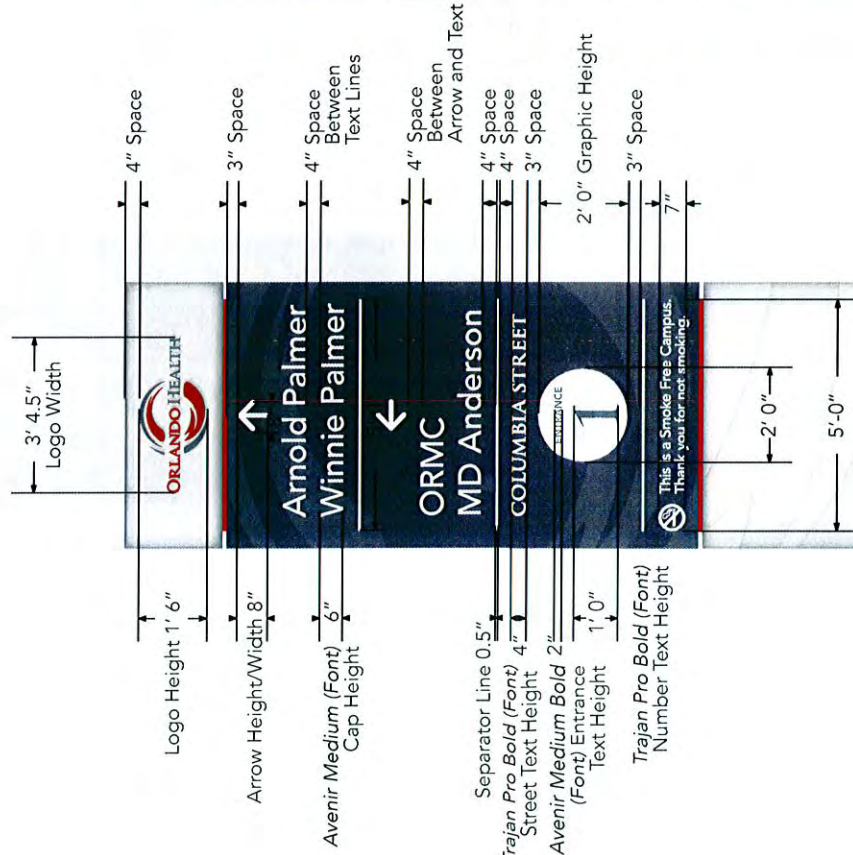

Sample Back

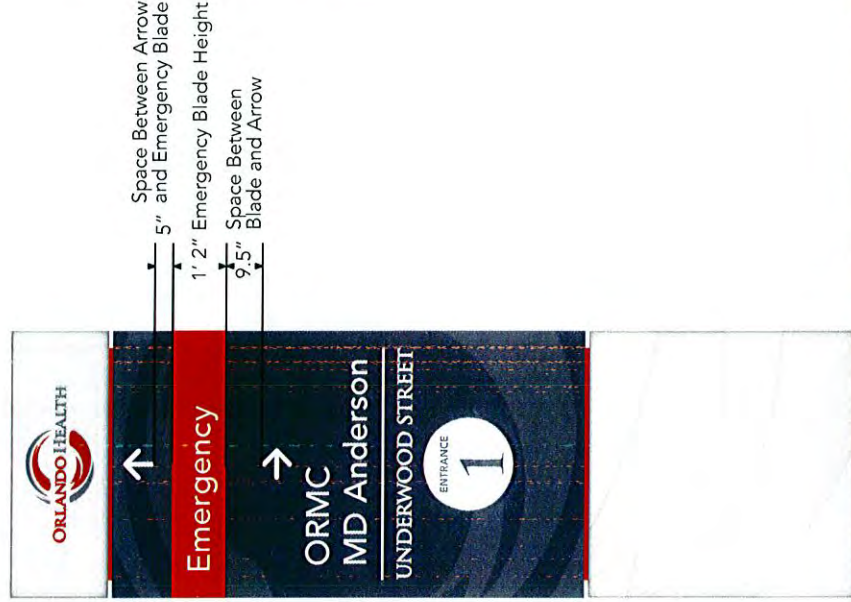





Orlando Health  
PD Sign Plan

Sign C —  
Hospital ID

Scale: 1/4" = 1'

Note: Drawing scale shown on plans is accurate for full size plans only. AECOM is not responsible for scale discrepancies caused by reduced size plans.

Description:  
Hospital ID – Internally Lit

Original Issue Date: 2012.07.30

Contact:  
Environmental Graphics/Wayfinding  
AECOM  
407-843-6552  
150 N Orange Avenue, Suite 200  
Orlando, Florida 32801

Typical Height = 15' 0"  
Typical Area per face = 89.81 sq. ft  
Typical Area per side = 8.68 sq. ft  
Typical Width = 6' 0"  
Typical Depth = 7"

Prepared By:



Front View

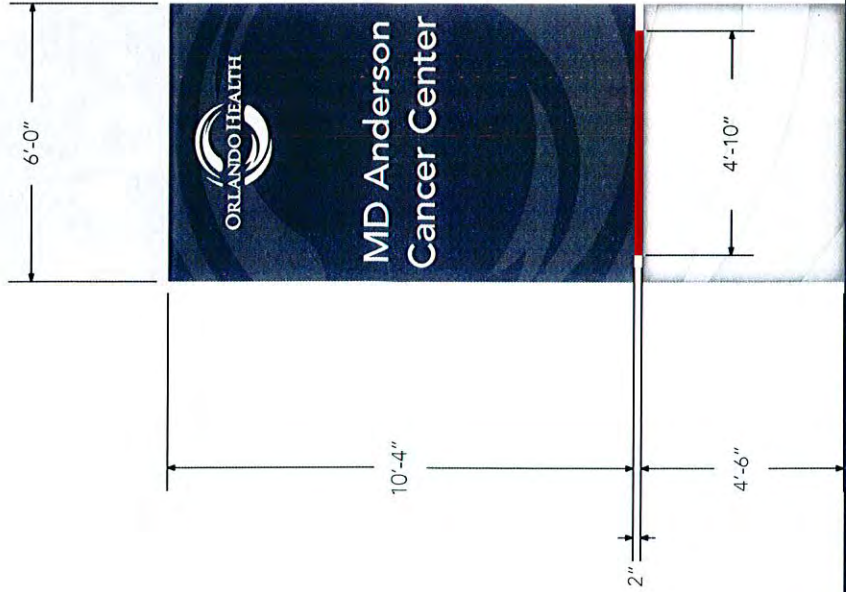

Side View

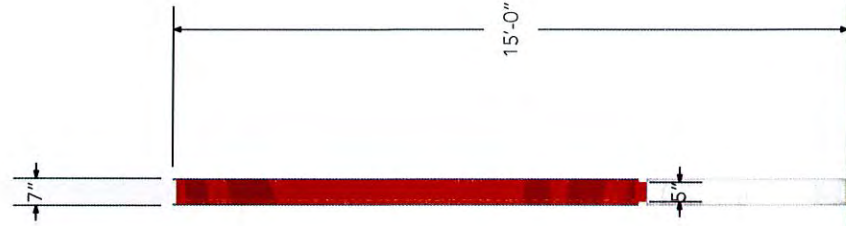

# MATERIALS

Front View

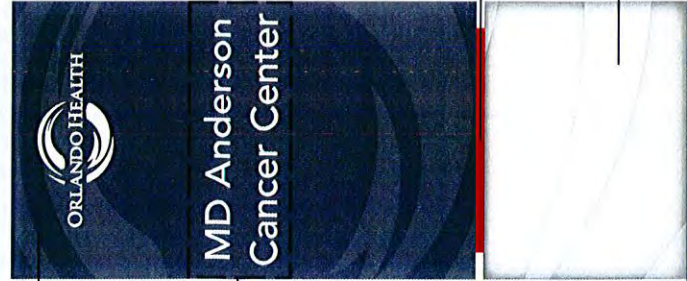



Aluminum Cabinet with Painted Logo Design (See Colors); Transparent White Acrylic Push-through Lettering/ Graphics; Internally Lit with White LED

Individual Aluminum Panel Painted to Match Cabinet Body; Transparent White Acrylic Push-through Lettering to Illuminate Copy; Internally Lit with White LED

All push-through illuminated graphics to be secured via clear acrylic backer panel. Secured with clips to internal supports

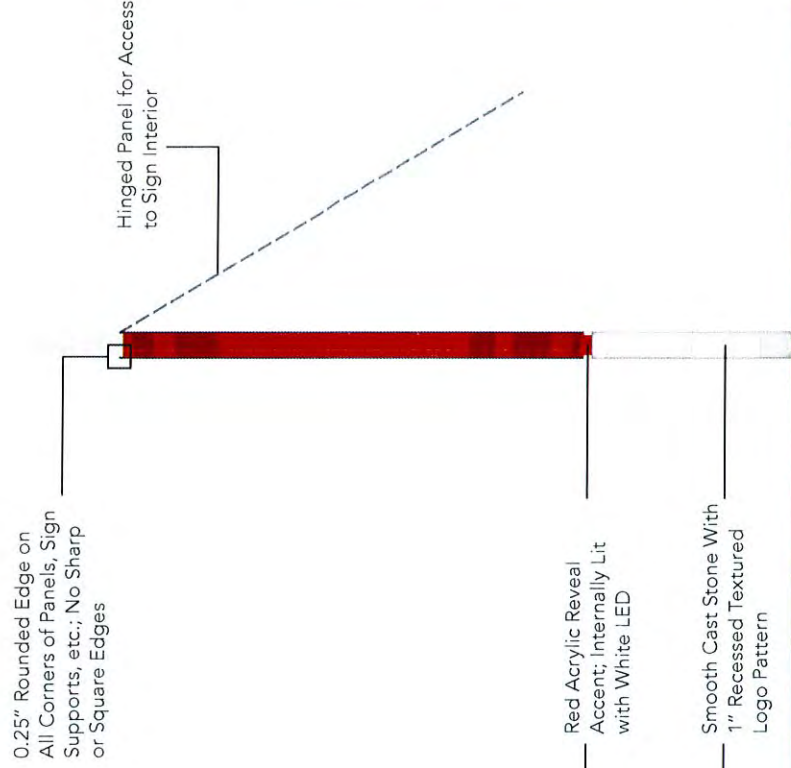
Side View



 <p><b>Orlando Health PD Sign Plan Sign C — Hospital ID</b></p>	<p><b>Scale: 1/4" = 1'</b></p> <p>Note: Drawing scale shown on plans is accurate for full size plans only. AECOM is not responsible for scale discrepancies caused by reduced size plans.</p>	<p><b>Description:</b> Hospital ID – Internally Lit</p>	<p><b>Original Issue Date:</b> 2012.07.30</p>	<p><b>Contact:</b> Environmental Graphics/Wayfinding AECOM 407-843-6552 150 N Orange Avenue, Suite 200 Orlando, Florida 32801</p>	<p>Typical Height = 15' 0" Typical Area per face = 89.81 sq. ft Typical Area per side = 8.68 sq. ft Typical Width = 6' 0" Typical Depth = 7"</p>	<p>Prepared By:</p> 
--	---	---	---	---	--	---



Front View

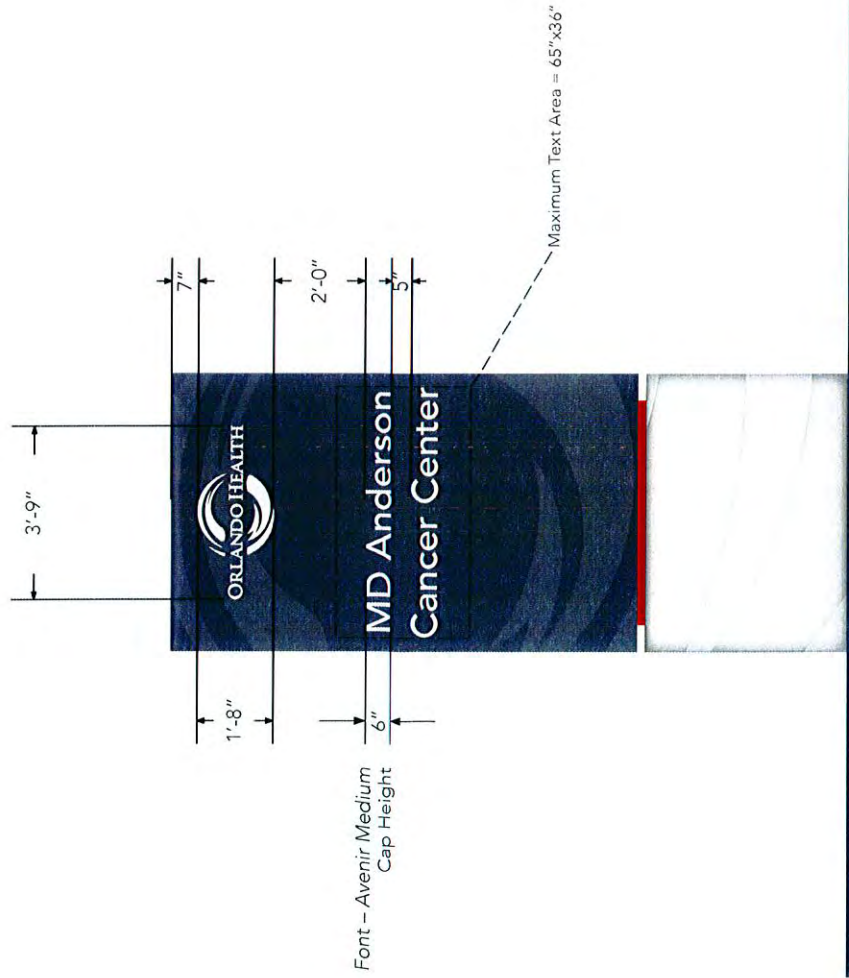

Side View

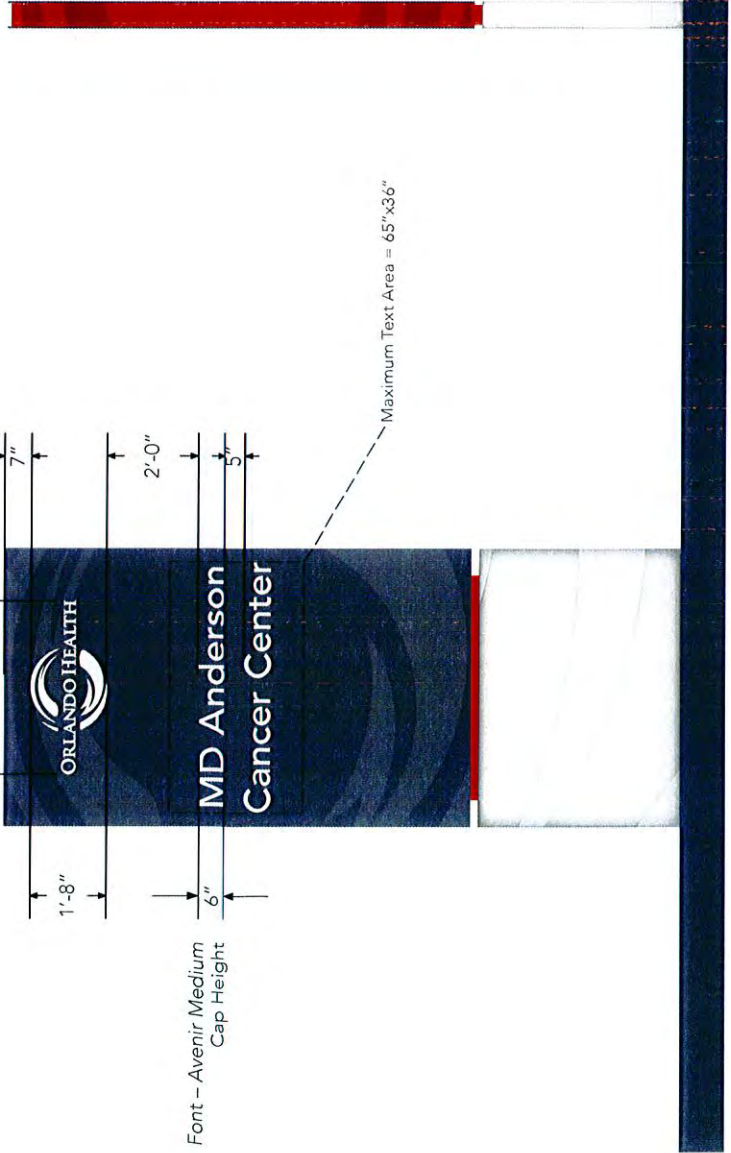

Orlando Health  
PD Sign Plan

Sign C —  
Hospital ID

Scale: 1/4" = 1'

Note: Drawing scale shown on plans is accurate for full size plans only. AECOM is not responsible for scale discrepancies caused by reduced size plans.

Description:  
Hospital ID – Internally Lit

Original Issue Date: 2012.07.30

Contact:  
Environmental Graphics/Wayfinding  
AECOM  
407-843-6552  
150 N Orange Avenue, Suite 200  
Orlando, Florida 32801

Typical Height = 15' 0"  
Typical Area per face = 89.81 sq. ft  
Typical Area per side = 8.68 sq. ft  
Typical Width = 6' 0"  
Typical Depth = 7"

Prepared By:





# DIMENSIONS & MATERIALS

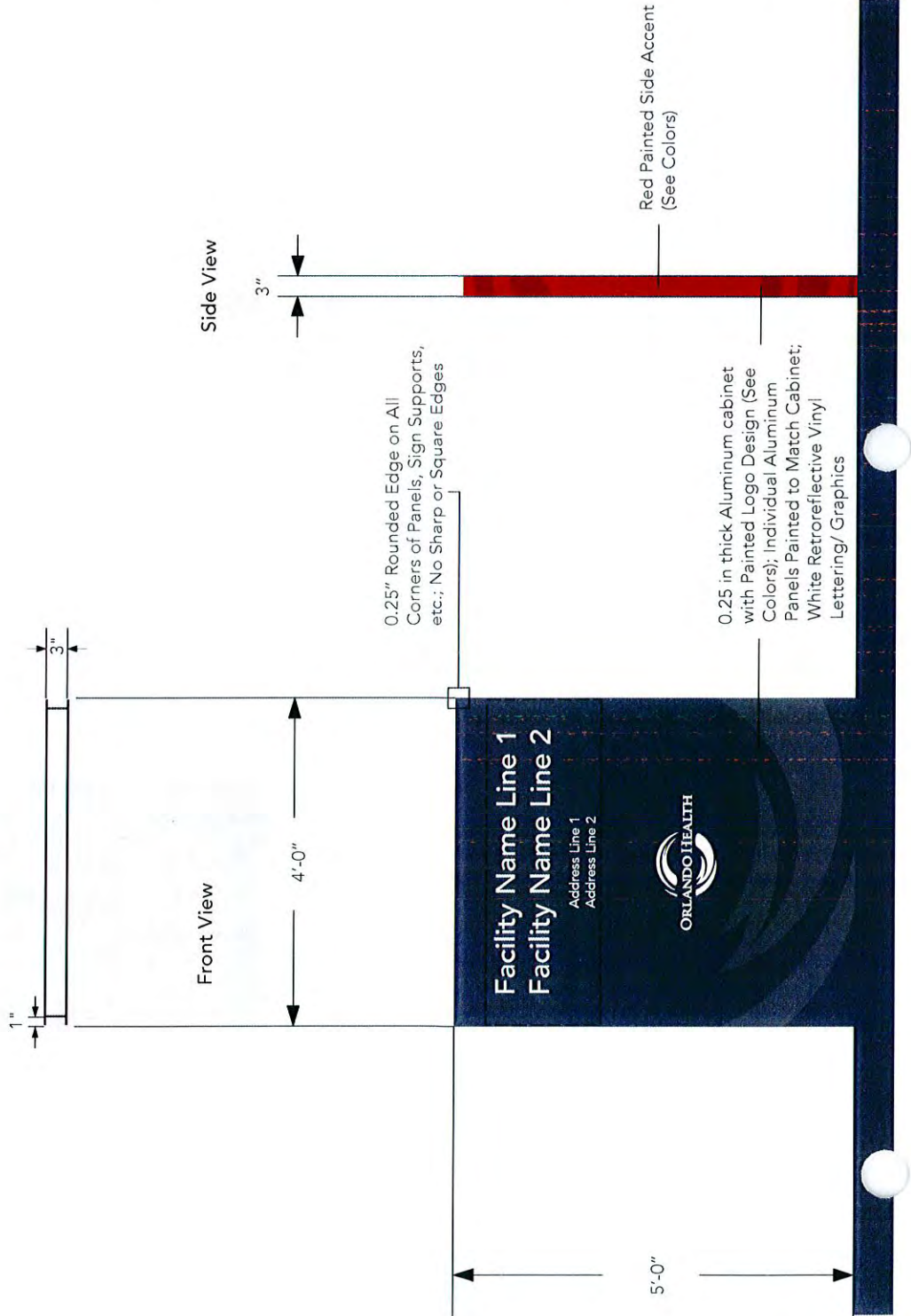

<b>Orlando Health PD Sign Plan Sign D — Building ID</b>	
<b>Scale: 1/2" = 1'</b> Note: Drawing scale shown on plans is accurate for full size plans only. AECOM is not responsible for scale discrepancies caused by reduced size plans.	
<b>Description:</b> Building ID	
<b>Original Issue Date:</b> 2012.07.30	
<b>Contact:</b> Environmental Graphics/Wayfinding AECOM 407-843-6552 150 N Orange Avenue, Suite 200 Orlando, Florida 32801	
<b>Typical Height = 5' 0"</b> <b>Typical Area per face = 20 sq. ft.</b> <b>Typical Area per side = 1.25 sq. ft.</b> <b>Typical Width = 4' 0"</b> <b>Typical Depth = 3"</b>	
Prepared By:	



Orlando Health  
 PD Sign Plan  
 Sign D —  
 Building ID

Scale: 1/2" = 1'  
 Note: Drawing scale shown on plans is accurate for full size plans only. AECOM is not responsible for scale discrepancies caused by reduced size plans.

Description:  
 Building ID

Original Issue Date: 2012.07.30

Contact:  
 Environmental Graphics/Wayfinding  
 AECOM  
 407-843-6552  
 150 N Orange Avenue, Suite 200  
 Orlando, Florida 32801

Typical Height = 5' 0"  
 Typical Area per face = 20 sq. ft.  
 Typical Area per side = 1.25 sq. ft.  
 Typical Width = 4' 0"  
 Typical Depth = 3"

Prepared By:  
**AECOM**

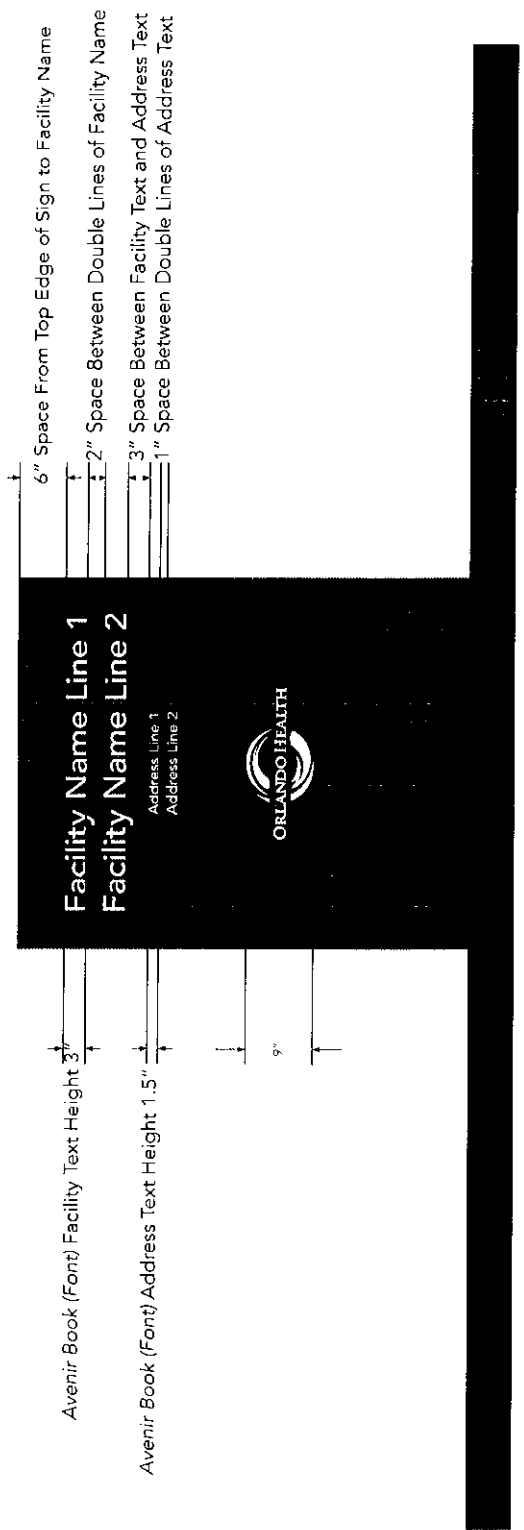

# DIMENSIONS & MATERIALS

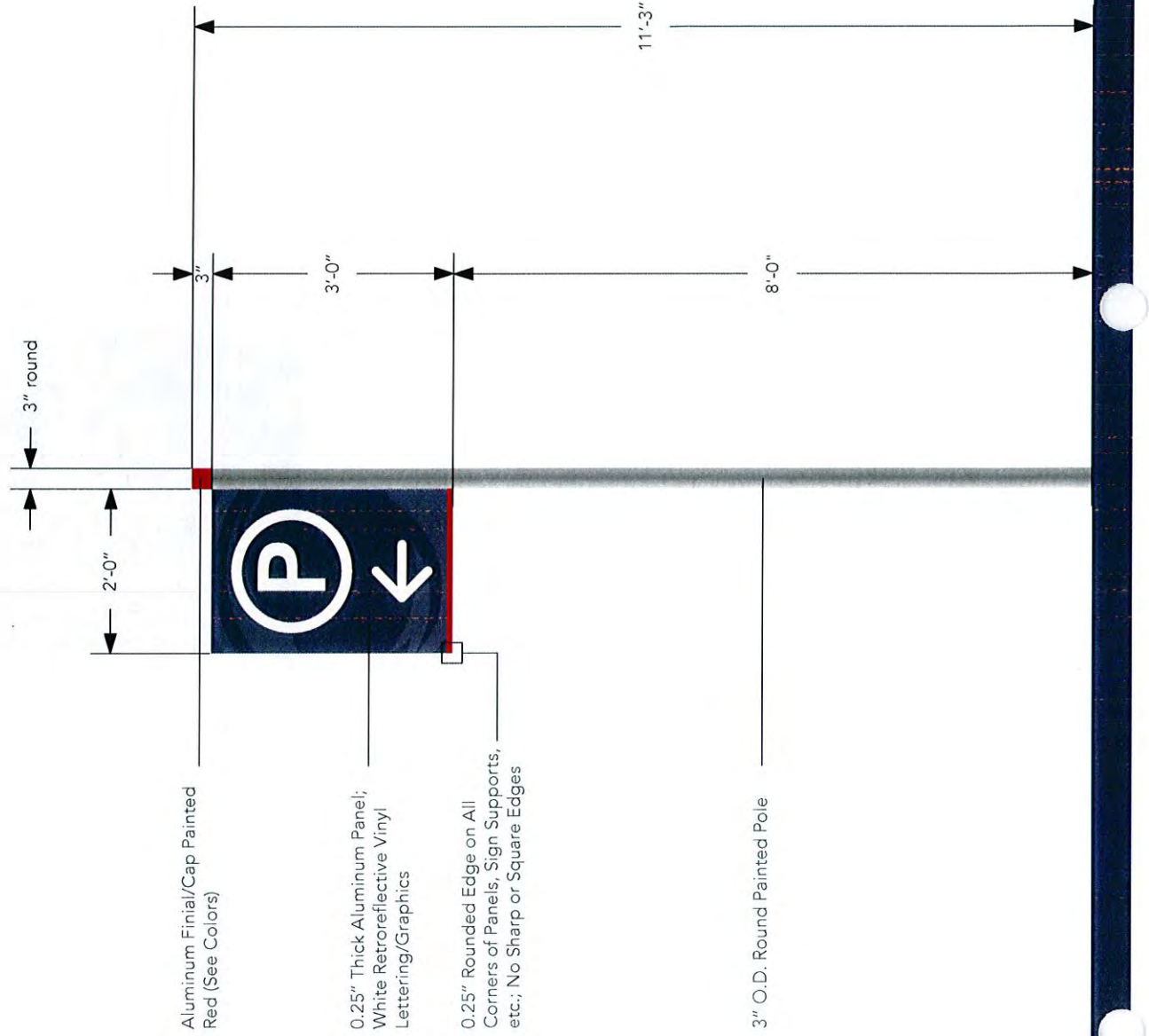

## Orlando Health PD Sign Plan Sign E — Parking ID/Directional

Scale: 1/2" = 1'

Note: Drawing scale shown on plans is accurate for full size plans only. AECOM is not responsible for scale discrepancies caused by reduced size plans.

Description:  
Parking ID/Directional

Original Issue Date: 2012.07.30

Contact:  
Environmental Graphics/Wayfinding  
AECOM  
407-843-6552  
150 N Orange Avenue, Suite 200  
Orlando, Florida 32801

Typical Height = 11' 3"  
Typical Area per face = 6 sq. ft.  
Typical Area per face = 9 sq. in.  
Typical Width = 2' 0"  
Typical Depth = 0.25" (panels)

Prepared By:







Orlando Health  
 PD Sign Plan  
 Sign E —  
 Parking ID/Directional

**Scale:** NTS  
 Note: Drawing scale shown on plans is accurate for full size plans only. AECOM is not responsible for scale discrepancies caused by reduced size plans.

**Description:**  
 Parking ID/Directional

**Original Issue Date:** 2012.07.30

**Contact:**  
 Environmental Graphics/Wayfinding  
 AECOM  
 407-843-6552  
 150 N Orange Avenue, Suite 200  
 Orlando, Florida 32801

Typical Height = 11' 3"  
 Typical Area per face = 6 sq. ft.  
 Typical Area per face = 9 sq. in.  
 Typical Width = 2' 0"  
 Typical Depth = 0.25" (panels)

Prepared By:  
**AECOM**

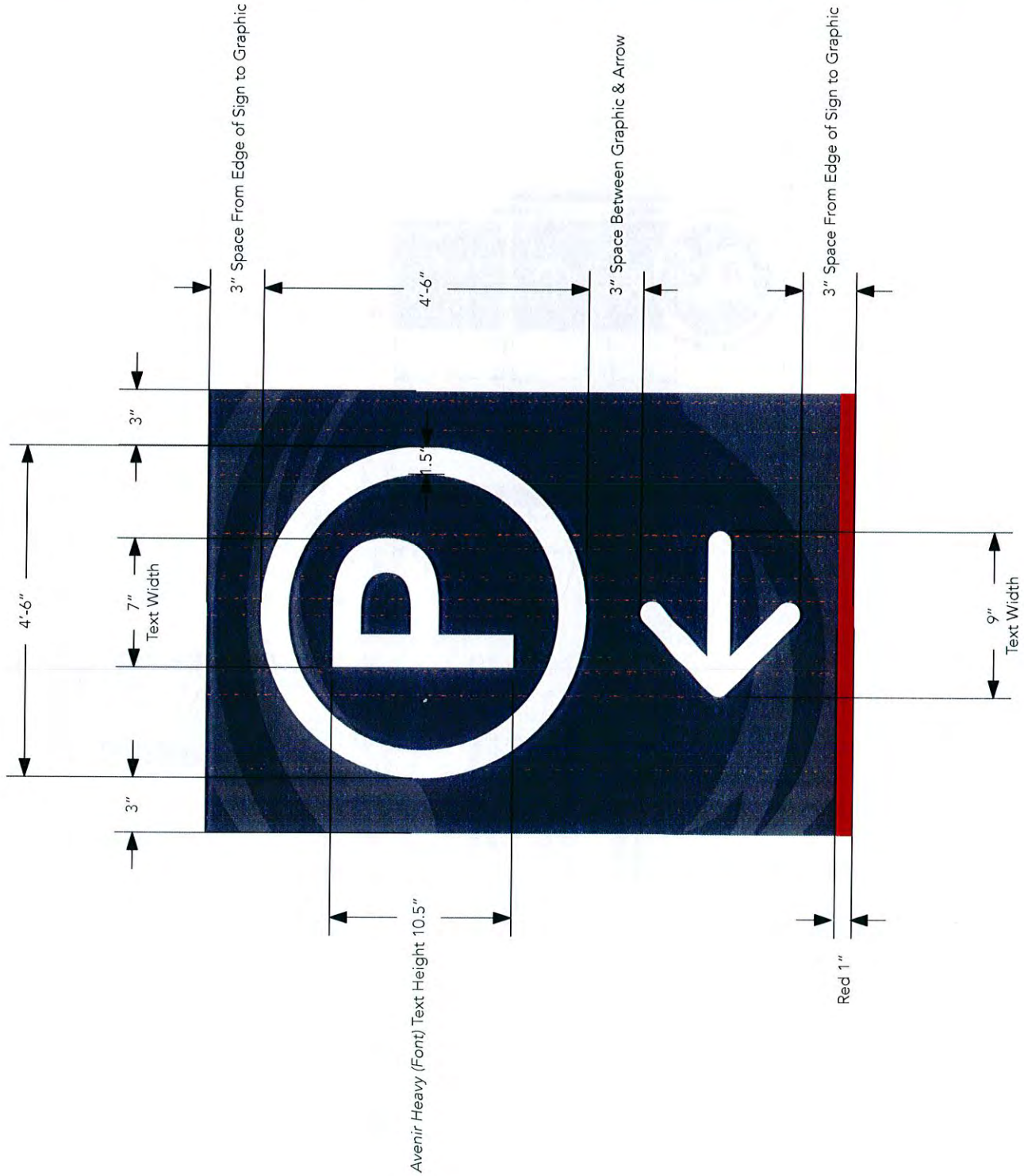

# DIMENSIONS & MATERIALS



Orlando Health  
PD Sign Plan

Sign F —  
C-Deck Parking Garage  
ID/Directional

Scale: 1/4" = 1'

Note: Drawing scale shown on plans is accurate for full size plans only. AECOM is not responsible for scale discrepancies caused by reduced size plans.

Description:  
Parking Garage ID/Directional

Original Issue Date: 2012.07.30

Contact:  
Environmental Graphics/Wayfinding  
AECOM  
407-843-6552  
150 N Orange Avenue, Suite 200  
Orlando, Florida 32801

Typical Height = 11' .625"  
Typical Area per face = 45.5 sq. ft.  
Typical Area per side = 6 sq. ft.  
Typical Width = 4' 0"  
Typical Depth = 10"

Prepared By:

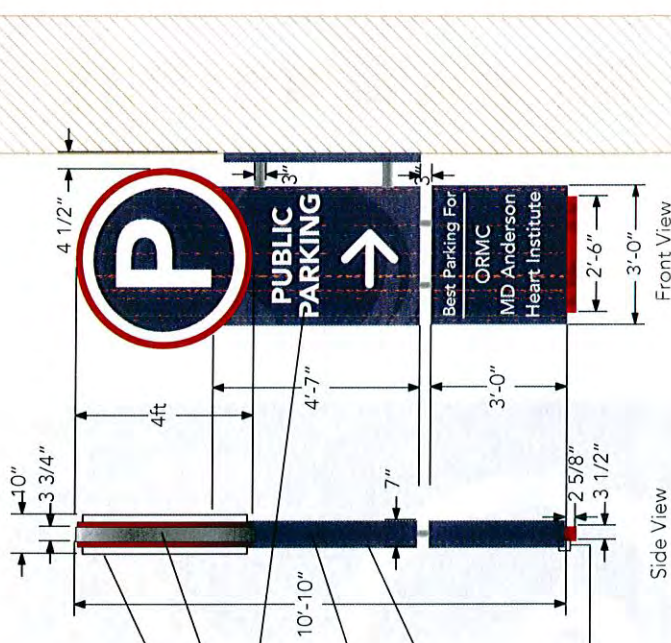

Acrylic reveal with aluminum face and push thru illuminated "P"

1in x 3.75in aluminum bar

All push-through illuminated graphics to be secured via clear acrylic backer panel. Secured with clips to internal supports.

Red Acrylic Reveal Accent with Logo Design (See Colors); Internally Lit with White LED

Aluminum Cabinet with Painted Logo Design (See Colors); Transparent White Acrylic Push-through Lettering/Graphics; Internally Lit with White LED

0.25" Rounded Edge on All Corners of Panels, Sign Supports, etc.; No Sharp or Square Edges



Illuminated content shown in white.

Final position to be determined at time of fabrication



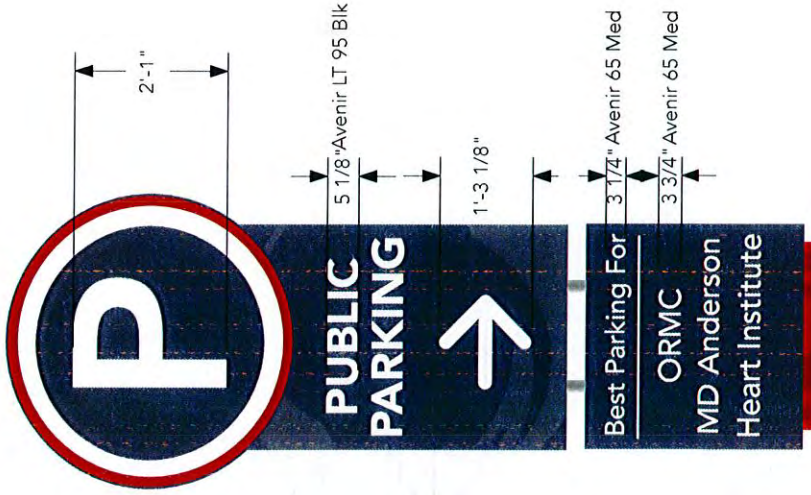

Orlando Health  
 PD Sign Plan  
 Sign F —  
 C-Deck Parking Garage  
 ID/Directional

Scale: NTS  
 Note: Drawing scale shown on plans is accurate for full size plans only. AECOM is not responsible for scale discrepancies caused by reduced size plans.

Description:  
 Parking Garage ID/Directional

Original Issue Date: 2012.07.30

Contact:  
 Environmental Graphics/Wayfinding  
 AECOM  
 407-843-6552  
 150 N Orange Avenue, Suite 200  
 Orlando, Florida 32801

Typical Height = 11' .625"  
 Typical Area per face = 45.5 sq. ft.  
 Typical Area per side = 6 sq. ft.  
 Typical Width = 4' 0"  
 Typical Depth = 10"

Prepared By:  
**AECOM**

# DIMENSIONS & MATERIALS



## Orlando Health PD Sign Plan

### Sign I — Vehicular Directional with Emergency (Solar Option)

Scale: 1/4" = 1'

Note: Drawing scale shown on plans is accurate for full size plans only. AECOM is not responsible for scale discrepancies caused by reduced size plans.

Description:  
Vehicular Directional with Emergency  
— Internally Lit, Solar

Original Issue Date: 2012.07.30

Contact:  
Environmental Graphics/Wayfinding  
AECOM  
407-843-6552  
150 N Orange Avenue, Suite 200  
Orlando, Florida 32801

Typical Height = 14' 10"  
Typical Area per face = 16.75 sq. ft.  
Typical Area per side = 1.15 sq. ft.  
Typical Width = 3' 8"  
Typical Depth = 5"

Prepared By:



Top View

All push-through illuminated graphics to be secured via clear acrylic backer panel. Secured with clips to internal supports.

Flat Solar Panel; 180° Horizontally at 30° Increment South Facing  
0.25" Rounded Edge on All Corners of Panels, Sign Supports, etc.; No Sharp or Square Edges

Painted Aluminum Cabinet Projected From Main Cabinet (See Colors); Transparent White Acrylic Push-through Lettering/Graphics; Internally Lit with White LED

Aluminum Cabinet with Painted Logo Design (See Colors); Transparent White Acrylic Push-through Lettering/Graphics; Internally Lit with White LED

6" Round Painted Pole

10" Round Painted Pole; Extruded Door with Hinge for Battery Packs; Water and Dust Resistant Lock

Side View

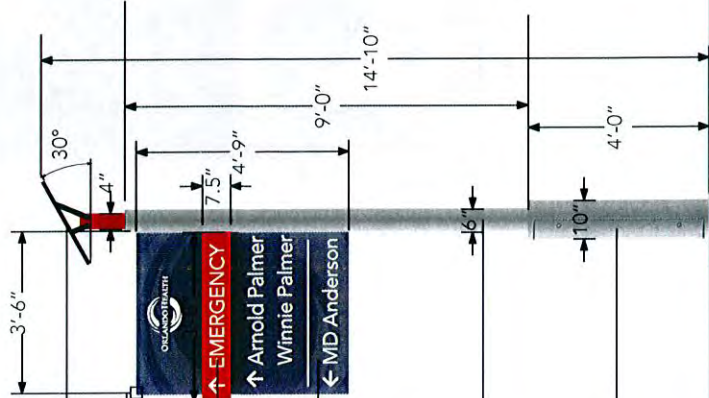
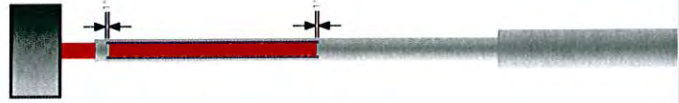



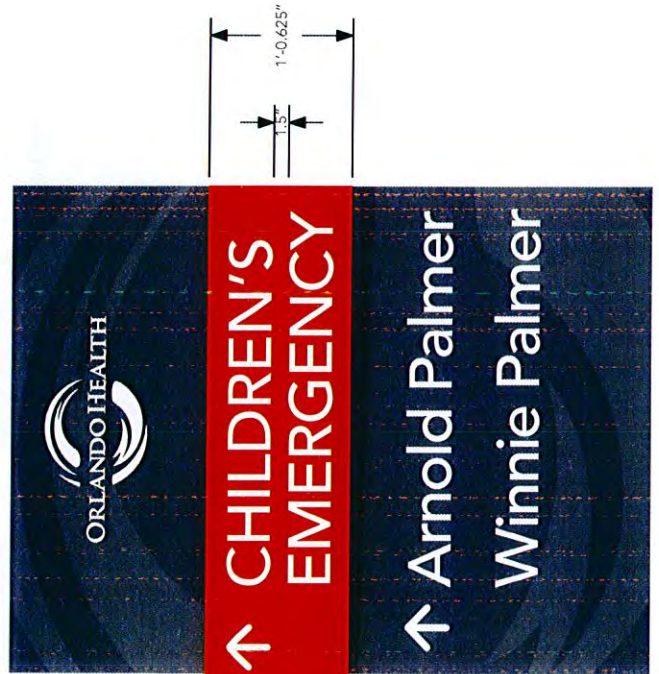
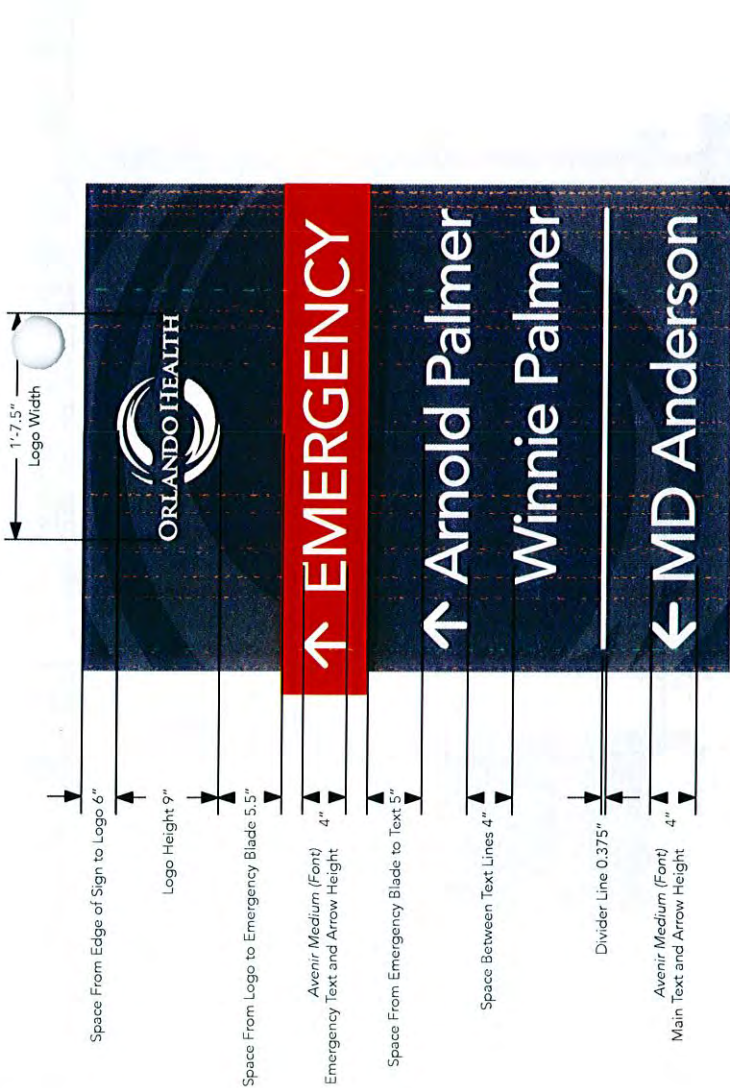

Orlando Health  
PD Sign Plan

Sign I — Vehicular  
Directional with  
Emergency (Solar Option)

Scale: NTS

Note: Drawing scale shown on plans is accurate for full size plans only. AECOM is not responsible for scale discrepancies caused by reduced size plans.

Description:  
Vehicular Directional with Emergency  
— Internally Lit, Solar

Original Issue Date: 2012.07.30

Contact:  
Environmental Graphics/Wayfinding  
AECOM  
407-843-6552  
150 N Orange Avenue, Suite 200  
Orlando, Florida 32801

Typical Height = 14' 10"  
Typical Area per face = 16.75 sq. ft.  
Typical Area per side = 1.15 sq. ft.  
Typical Width = 3' 8"  
Typical Depth = 5"

Prepared By:  
**AECOM**

# DIMENSIONS & MATERIALS



## Orlando Health PD Sign Plan

### Sign J — Vehicular Directional with Emergency

Scale: 1/4" = 1'

Note: Drawing scale shown on plans is accurate for full size plans only. AECOM is not responsible for scale discrepancies caused by reduced size plans.

Description:  
Vehicular Directional with Emergency

Original Issue Date: 2012.07.30

Contact:  
Environmental Graphics/Wayfinding  
AECOM  
407-843-6552  
150 N Orange Avenue, Suite 200  
Orlando, Florida 32801

Typical Height = 13' 6"  
Typical Area per face = 16.75 sq. ft.  
Typical Area per face = 1.15 sq. ft.  
Typical Width = 3' 8"  
Typical Depth = 5"

Prepared By:



Top View

All push-through illuminated graphics to be secured via clear acrylic backer panel. Secured with clips to internal supports.

Flat Solar Panel; 180° Horizontally at 30° Increment South Facing

0.25" Rounded Edge on All Corners of Panels, Sign Supports, etc.; No Sharp or Square Edges

Painted Aluminum Cabinet Projected From Main Cabinet (See Colors); Transparent White Acrylic Push-through Lettering/Graphics; Internally Lit with White LED

Aluminum Cabinet with Painted Logo Design (See Colors); Transparent White Acrylic Push-through Lettering/Graphics; Internally Lit with White LED

6" Round Painted Pole

10" Round Painted Pole; Extruded Door with Hinge for Battery Packs; Water and Dust Resistant Lock

Side View

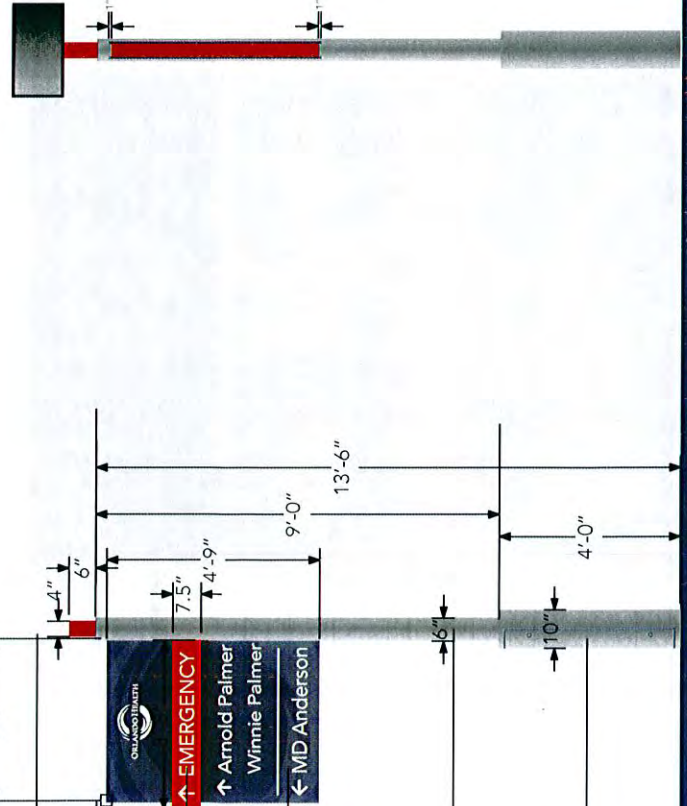



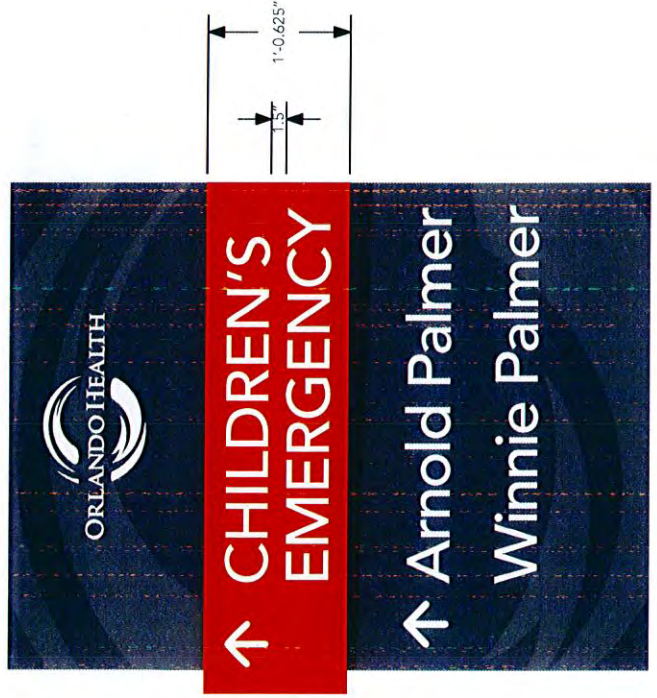
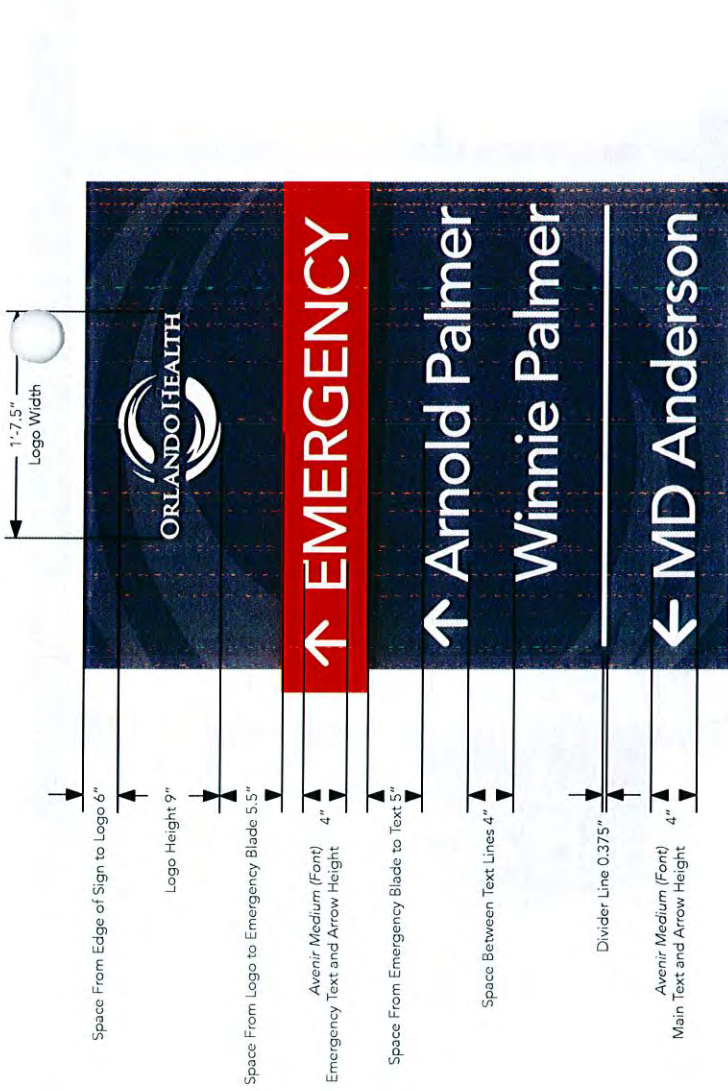

Orlando Health  
PD Sign Plan

Sign J — Vehicular  
Directional with  
Emergency

Scale: NTS

Note: Drawing scale shown on plans is accurate for full size plans only. AECOM is not responsible for scale discrepancies caused by reduced size plans.

Description:  
Vehicular Directional with Emergency

Original Issue Date: 2012.07.30

Contact:  
Environmental Graphics/Wayfinding  
AECOM  
407-843-6552  
150 N Orange Avenue, Suite 200  
Orlando, Florida 32801

Typical Height = 13' 6"  
Typical Area per face = 16.75 sq. ft.  
Typical Area per face = 1.15 sq. ft.  
Typical Width = 3' 8"  
Typical Depth = 5"

Prepared By:



# DIMENSIONS & MATERIALS



## Orlando Health PD Sign Plan Sign K — Vehicular Directional (Solar Option)

Scale: 1/4" = 1'

Note: Drawing scale shown on plans is accurate for full size plans only. AECOM is not responsible for scale discrepancies caused by reduced size plans.

Description:  
Vehicular Directional  
— Internally Lit, Solar

Original Issue Date: 2012.07.30

Contact:  
Environmental Graphics/Wayfinding  
AECOM  
407-843-6552  
150 N Orange Avenue, Suite 200  
Orlando, Florida 32801

Typical Height = 14' 10"  
Typical Area per face = 16.62 sq. ft.  
Typical Area per face = 1 sq. ft.  
Typical Width = 3' 6"  
Typical Depth = 5"

Prepared By:



Top View

All push-through illuminated graphics to be secured via clear acrylic backer panel. Secured with clips to internal supports.

Flat Solar Panel; 180° Horizontally at 30° Increment South Facing  
0.25" Rounded Edge on All Corners of Panels, Sign Supports, etc.; No Sharp or Square Edges

Painted Aluminum Cabinet Projected From Main Cabinet (See Colors); Transparent White Acrylic Push-through Lettering/Graphics; Internally Lit with White LED

Aluminum Cabinet with Painted Logo Design (See Colors); Transparent White Acrylic Push-through Lettering/Graphics; Internally Lit with White LED

6" Round Painted Pole

10" Round Painted Pole; Extruded Door with Hinge for Battery Packs; Water and Dust Resistant Lock

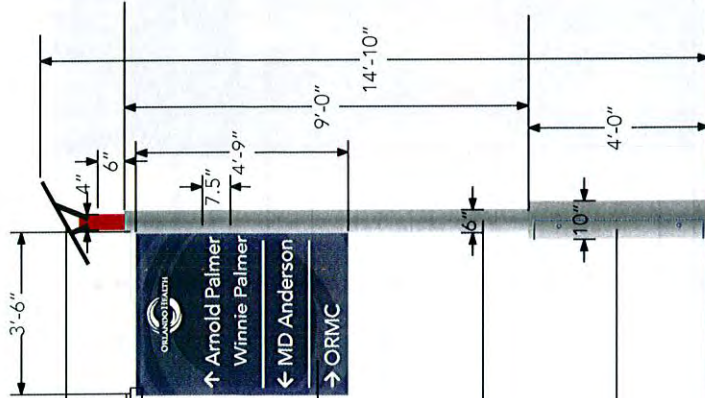

Side View





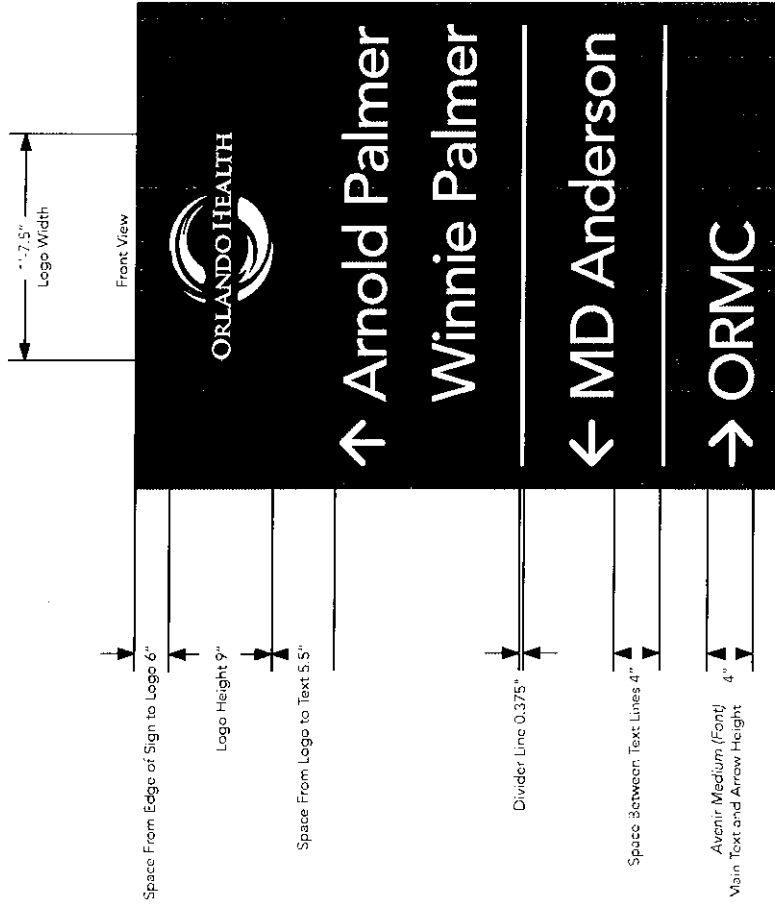

Graphic content shall vary by sign location.  
Please see message schedule for exact content.



Orlando Health  
PD Sign Plan

Sign K —  
Vehicular Directional  
(Solar Option)

Scale: NTS

Note: Drawing scale shown on plans is accurate for full size plans only. AECOM is not responsible for scale discrepancies caused by reduced size plans.

Description:  
Vehicular Directional  
— Internally Lit, Solar

Original Issue Date: 2012.07.30

Contact:  
Environmental Graphics/Wayfinding  
AECOM  
407-843-6552  
150 N Orange Avenue, Suite 200  
Orlando, Florida 32801

Typical Height = 14' 10"  
Typical Area per face = 16.62 sq. ft.  
Typical Area per face = 1 sq. ft.  
Typical Width = 3' 6"  
Typical Depth = 5"

Prepared By:



# DIMENSIONS & MATERIALS



## Orlando Health PD Sign Plan

### Sign L — Vehicular Directional

Scale: 1/4" = 1'

Note: Drawing scale shown on plans is accurate for full size plans only. AECOM is not responsible for scale discrepancies caused by reduced size plans.

Description:  
Vehicular Directional

Original Issue Date: 2012.07.30

Contact:  
Environmental Graphics/Wayfinding  
AECOM  
407-843-6552  
150 N Orange Avenue, Suite 200  
Orlando, Florida 32801

Typical Height = 13' 6"  
Typical Area per face = 16.62 sq. ft.  
Typical Area per side = 1 sq. ft.  
Typical Width = 3' 6"  
Typical Depth = 5"

Prepared By:



Top View

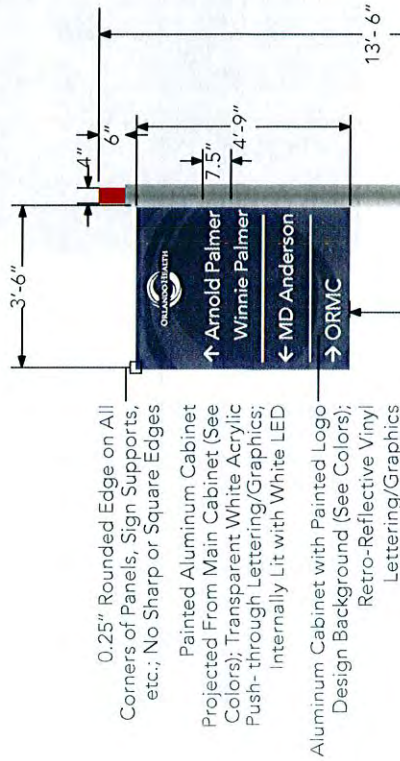

Side View



0.25" Rounded Edge on All Corners of Panels, Sign Supports, etc.; No Sharp or Square Edges

Painted Aluminum Cabinet Projected From Main Cabinet (See Colors); Transparent White Acrylic Push-through Lettering/Graphics; Internally Lit with White LED

Aluminum Cabinet with Painted Logo Design Background (See Colors); Retro-Reflective Vinyl Lettering/Graphics



6" Round Painted Pole

10" Round Painted Pole; Extruded Door with Hinge for Battery Packs; Water and Dust Resistant Lock

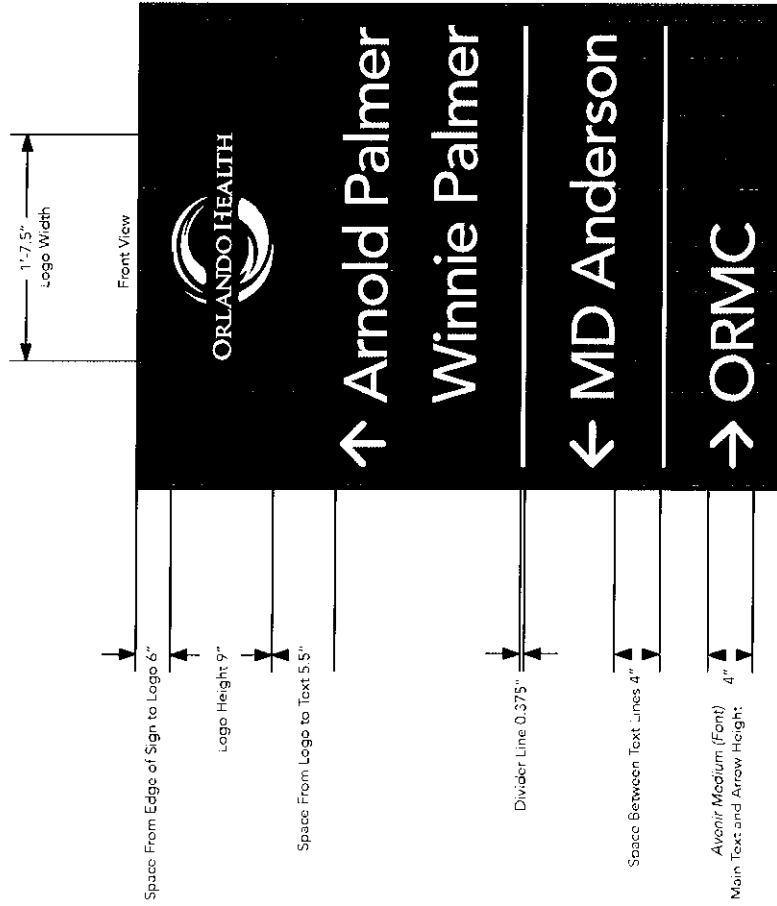



Graphic content shall vary by sign location. Please see message schedule for exact content.

 <p><b>Orlando Health</b> PD Sign Plan</p> <p><b>Sign L —</b> Vehicular Directional</p>	<p><b>Scale:</b> NTS</p> <p>Note: Drawing scale shown on plans is accurate for full size plans only. AECOM is not responsible for scale discrepancies caused by reduced size plans.</p>
<p><b>Description:</b> Vehicular Directional</p>	<p><b>Original Issue Date:</b> 2012.07.30</p>
<p><b>Contact:</b> Environmental Graphics/Wayfinding AECOM 407-843-6552 150 N Orange Avenue, Suite 200 Orlando, Florida 32801</p>	<p>Typical Height = 13' 6"</p> <p>Typical Area per face = 16.62 sq. ft.</p> <p>Typical Area per side = 1 sq. ft.</p> <p>Typical Width = 3' 6"</p> <p>Typical Depth = 5"</p>
<p>Prepared By:</p> 	

# DIMENSIONS & MATERIALS



## Orlando Health PD Sign Plan

### Sign M — Pedestrian Directional

Scale: 1/4" = 1'

Note: Drawing scale shown on plans is accurate for full size plans only. AECOM is not responsible for scale discrepancies caused by reduced size plans.

Description:  
Pedestrian Directional

Original Issue Date: 2012.07.30

Contact:  
Environmental Graphics/Wayfinding  
AECOM  
407-843-6552  
150 N Orange Avenue, Suite 200  
Orlando, Florida 32801

Maximum Height = 11' 5"  
Maximum Area per face = 8.5 sq. ft.  
Maximum Area per side = 11.25 sq. in.  
Maximum Width = 2' 3"  
Maximum Depth = 0.25"

Prepared By:



Front & Back View

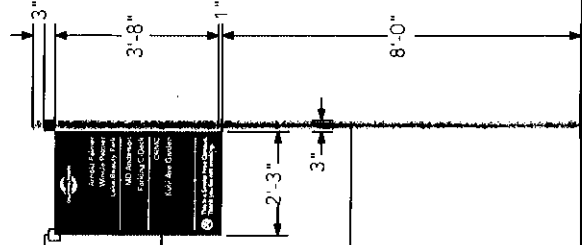

0.25" Rounded Edge on All Corners of Panels, Sign Supports, etc.; No Sharp or Square Edges

0.25" Thick Aluminum Blade Sign with Painted Background.  
Lettering/Graphics: Applied Vinyl.

3" Round Painted Aluminum Pole

# Orlando Health PD Sign Plan

## Sign M — Pedestrian Directional

### Scale: NTS

Note: Drawing scale shown on plans is accurate for full size plans only. AECOM is not responsible for scale discrepancies caused by reduced size plans.

Description:  
Pedestrian Directional

Original Issue Date: 2012.07.30

Contact:  
Environmental Graphics/Wayfinding  
AECOM  
407-843-6552  
150 N Orange Avenue, Suite 200  
Orlando, Florida 32801

Typical Height = 11' 5"  
Typical Area per face = 8.5 sq. ft.  
Typical Area per side = 11.25 sq. in.  
Typical Width = 2' 3"  
Typical Depth = 0.25"

Prepared By:

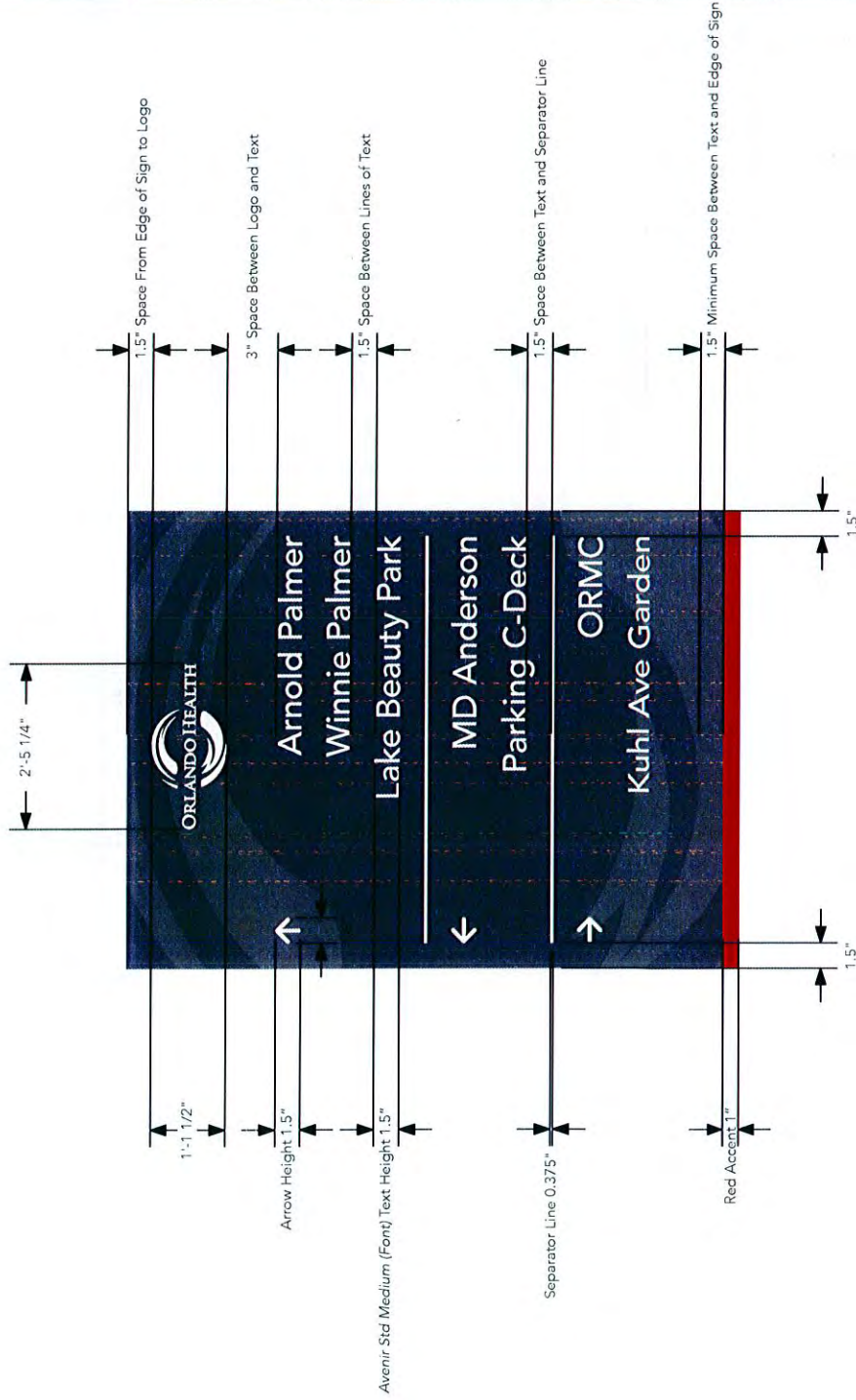

Graphic content shall vary by sign location;  
Please see message schedule for exact content.



# DIMENSIONS & MATERIALS

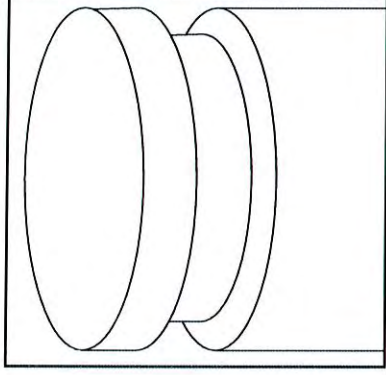

Finial Detail

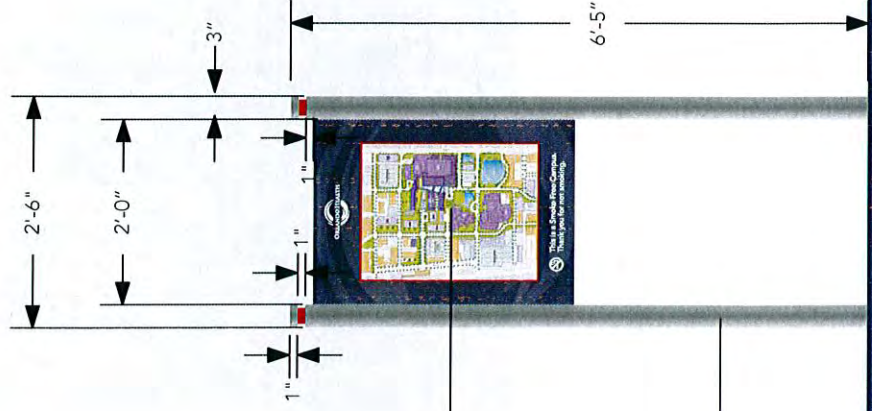

0.25" Thick High Pressure  
Laminate Phenolic Resin Panel  
with 0.25" Thick Aluminum  
Backer Plate; Printed Graphics

3" Round Aluminum Painted Pole



## Orlando Health PD Sign Plan Sign N — Pedestrian Kiosk Map

**Scale: 1/2" = 1'**  
Note: Drawing scale shown on plans is accurate for full size plans only. AECOM is not responsible for scale discrepancies caused by reduced size plans.

**Description:**  
Pedestrian Kiosk Map

**Original Issue Date:** 2012.07.30

**Contact:**  
Environmental Graphics/Wayfinding  
AECOM  
407-843-6552  
150 N Orange Avenue, Suite 200  
Orlando, Florida 32801

Typical Height = 11' 5"  
Typical Area per face = 5.83 sq. ft.  
Typical Width = 2' 3"  
Typical Depth = 0.25"





Orlando Health  
 PD Sign Plan  
 Sign N —  
 Pedestrian Kiosk Map



Fabricator shall not recreate any artwork. Final artwork shall be supplied by Client/Designer

Scale: NTS

Note: Drawing scale shown on plans is accurate for full size plans only. AECOM is not responsible for scale discrepancies caused by reduced size plans.

Description:  
 Pedestrian Kiosk Map

Original Issue Date: 2012.07.30

Contact:  
 Environmental Graphics/Wayfinding  
 AECOM  
 407-843-6552  
 150 N Orange Avenue, Suite 200  
 Orlando, Florida 32801

Typical Height = 11' 5"  
 Typical Area per face = 5.83 sq. ft.  
 Typical Width = 2' 3"  
 Typical Depth = 0.25"

Prepared By:



# DIMENSIONS & MATERIALS

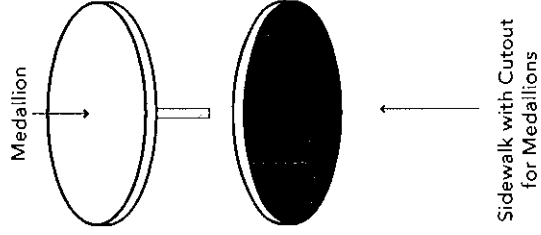
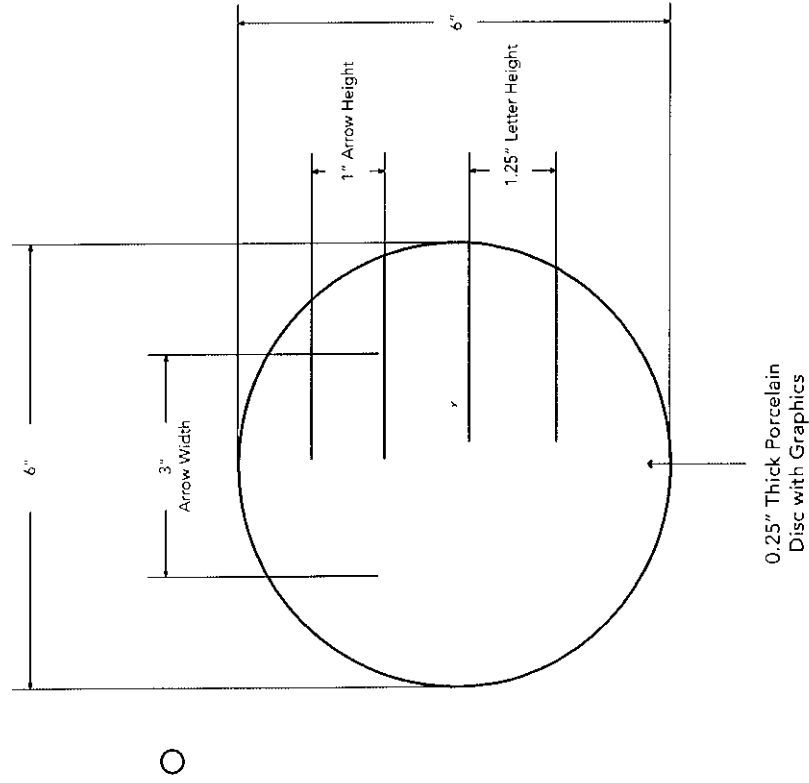
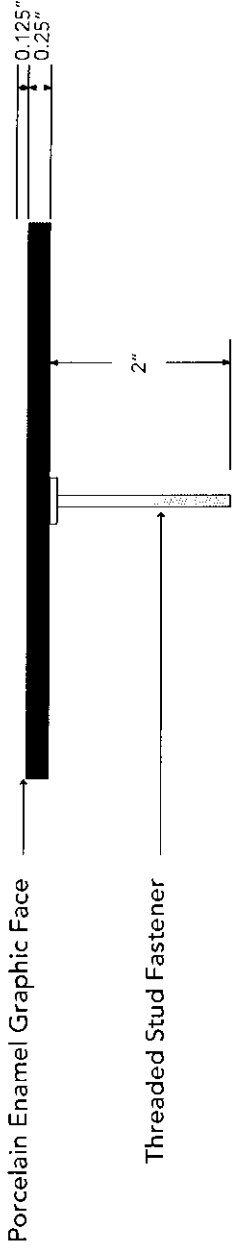

 <p><b>Orlando Health</b> PD Sign Plan</p> <p><b>Sign O —</b> Sidewalk Directional Medallions</p>	<p><b>Scale:</b> NTS</p> <p>Note: Drawing scale shown on plans is accurate for full size plans only. AECOM is not responsible for scale discrepancies caused by reduced size plans.</p>
<p><b>Description:</b> Sidewalk Directional Medallions</p>	<p><b>Original Issue Date:</b> 2012.07.30</p>
<p><b>Contact:</b> Environmental Graphics/Wayfinding AECOM 407-843-6552 150 N Orange Avenue, Suite 200 Orlando, Florida 32801</p>	<p>Typical Height = 6" Typical Area per medallion = 28.25 sq. in. Typical Width = 6" Typical Depth = 0.125"</p>
<p>Prepared By: <b>AECOM</b></p>	





Orlando Health  
PD Sign Plan  
Sign O —  
Sidewalk Directional  
Medallions

Scale: NTS

Note: Drawing scale shown on plans is accurate for full size plans only. AECOM is not responsible for scale discrepancies caused by reduced size plans.

Description:  
Sidewalk Directional Medallions

Original Issue Date: 2012.07.30

Contact:  
Environmental Graphics/Wayfinding  
AECOM  
407-843-6552  
150 N Orange Avenue, Suite 200  
Orlando, Florida 32801

Typical Height = 6"  
Typical Area per medallion = 28.25 sq. in.  
Typical Width = 6"  
Typical Depth = 0.125"

Prepared By:







Orlando Health  
PD Sign Plan

Sign R —  
B-Deck Garage  
Parking ID

Scale: NTS

Note: Drawing scale shown on plans is accurate for full size plans only. AECOM is not responsible for scale discrepancies caused by reduced size plans.

Description:  
B-Deck Garage Parking ID

Original Issue Date: 2012.07.30

Contact:  
Environmental Graphics/Wayfinding  
AECOM  
407-843-6552  
150 N Orange Avenue, Suite 200  
Orlando, Florida 32801

Typical Height = 56' 0"  
Typical Area = 29.75 sq. ft. (face)  
Typical Area = 4.25 sq. ft. (side)  
Typical Width = 43' 0"  
Typical Depth = 2"

Prepared By:

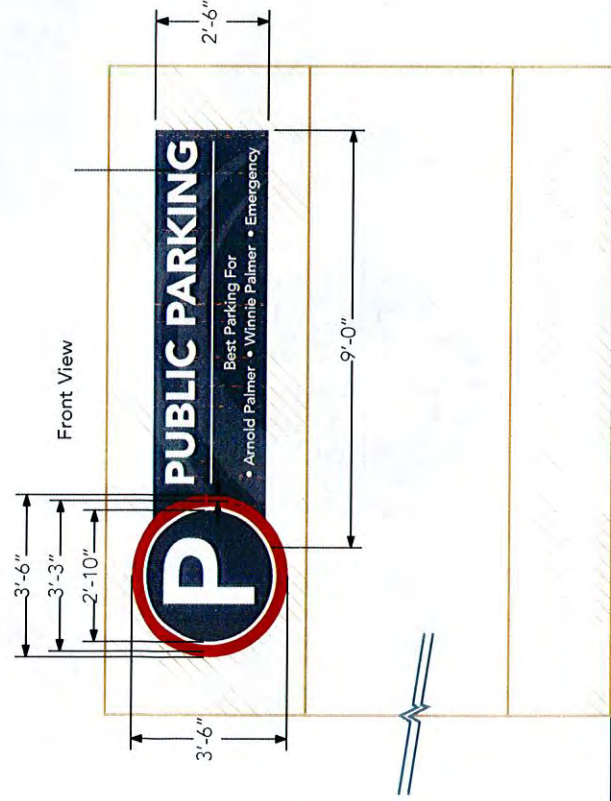
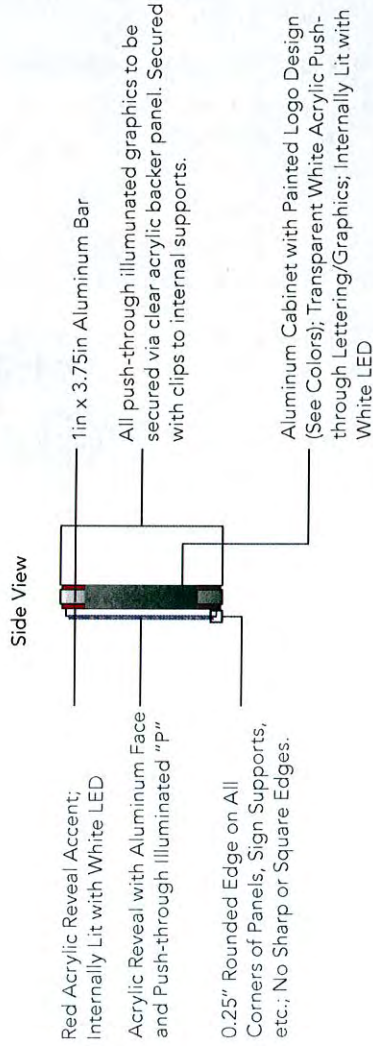





Orlando Health  
 PD Sign Plan  
 Sign R —  
 B-Deck Garage  
 Parking ID

Scale: 1/2" = 1'  
 Note: Drawing scale shown on plans is accurate for full size plans only. AECOM is not responsible for scale discrepancies caused by reduced size plans.

Description:  
 B-Deck Garage Parking ID

Original Issue Date: 2012.07.30

Contact:  
 Environmental Graphics/Wayfinding  
 AECOM  
 407-843-6552  
 150 N Orange Avenue, Suite 200  
 Orlando, Florida 32801

Typical Height = 56' 0"  
 Typical Area = 29.75 sq. ft. (face)  
 Typical Area = 4.25 sq. ft. (side)  
 Typical Width = 43' 0"  
 Typical Depth = 2"

Prepared By:  
**AECOM**

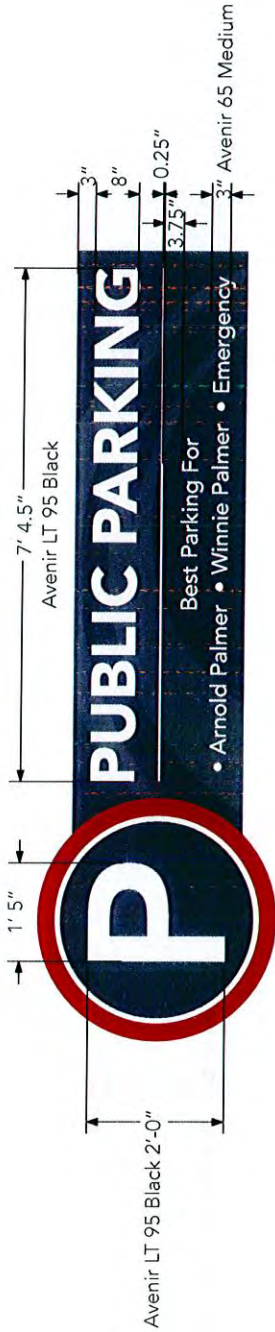

## Sign Location Maps

The maps on the following pages illustrate the location of signs by type. The maps include:

- o Gateway Directional Signs
- o Hospital ID Signs
- o Building ID Signs
- o Parking Signs
- o City of Orlando Directional Signs
- o Vehicular Directional Signs
- o Pedestrian Directional Signs
- o Pedestrian Kiosk Maps
- o Pedestrian Medallions
- o Other ID Signs
- o High Rise Signs



Legend	
	Arnold Palmer Hospital
	Winnie Palmer Hospital
	ORMC
	MD Anderson
	Hospital Entry
	Hospital Loading
	Emergency
	Major Gateway Directional
	Minor Gateway Directional



**Scale: NTS**

Note: Drawing scale shown on plans is accurate for full size plans only. AECOM is not responsible for scale discrepancies caused by reduced size plans.

**Description:**  
Sign Locations for Gateways

**Original Issue Date:** 2012.04.25

**Contact:**  
Environmental Graphics/Wayfinding  
AECOM  
407-843-6552  
150 N Orange Avenue, Suite 200  
Orlando, Florida 32801

Prepared By:

**AECOM**

Legend	
	Arnold Palmer Hospital
	Winnie Palmer Hospital
	ORMC
	MD Anderson
	Hospital Entry
	Hospital Loading
	Emergency
	Hospital Building ID



**ORLANDO HEALTH**

# Orlando Health PD Sign Plan Sign Location Plan — Hospital ID

**Scale:** NTS  
 Note: Drawing scale shown on plans is accurate for full size plans only. AECOM is not responsible for scale discrepancies caused by reduced size plans.

**Description:**  
 Sign Locations for Hospital ID

**Original Issue Date:** 2012.04.25

**Contact:**  
 Environmental Graphics/Wayfinding  
 AECOM  
 407-843-6552  
 150 N Orange Avenue, Suite 200  
 Orlando, Florida 32801

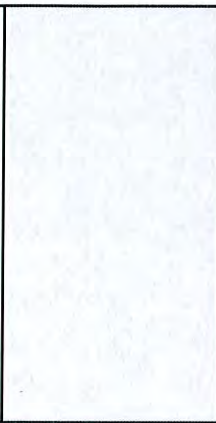

**Prepared By:**  
**AECOM**





# Orlando Health PD Sign Plan Sign Location Plan — Building ID

**Scale:** NTS  
 Note: Drawing scale shown on plans is accurate for full size plans only. AECOM is not responsible for scale discrepancies caused by reduced size plans.

**Description:**  
 Sign Locations for Building ID

**Original Issue Date:** 2012.04.25

**Contact:**  
 Environmental Graphics/Wayfinding  
 AECOM  
 407-843-6552  
 150 N Orange Avenue, Suite 200  
 Orlando, Florida 32801



Prepared By:  
**AECOM**

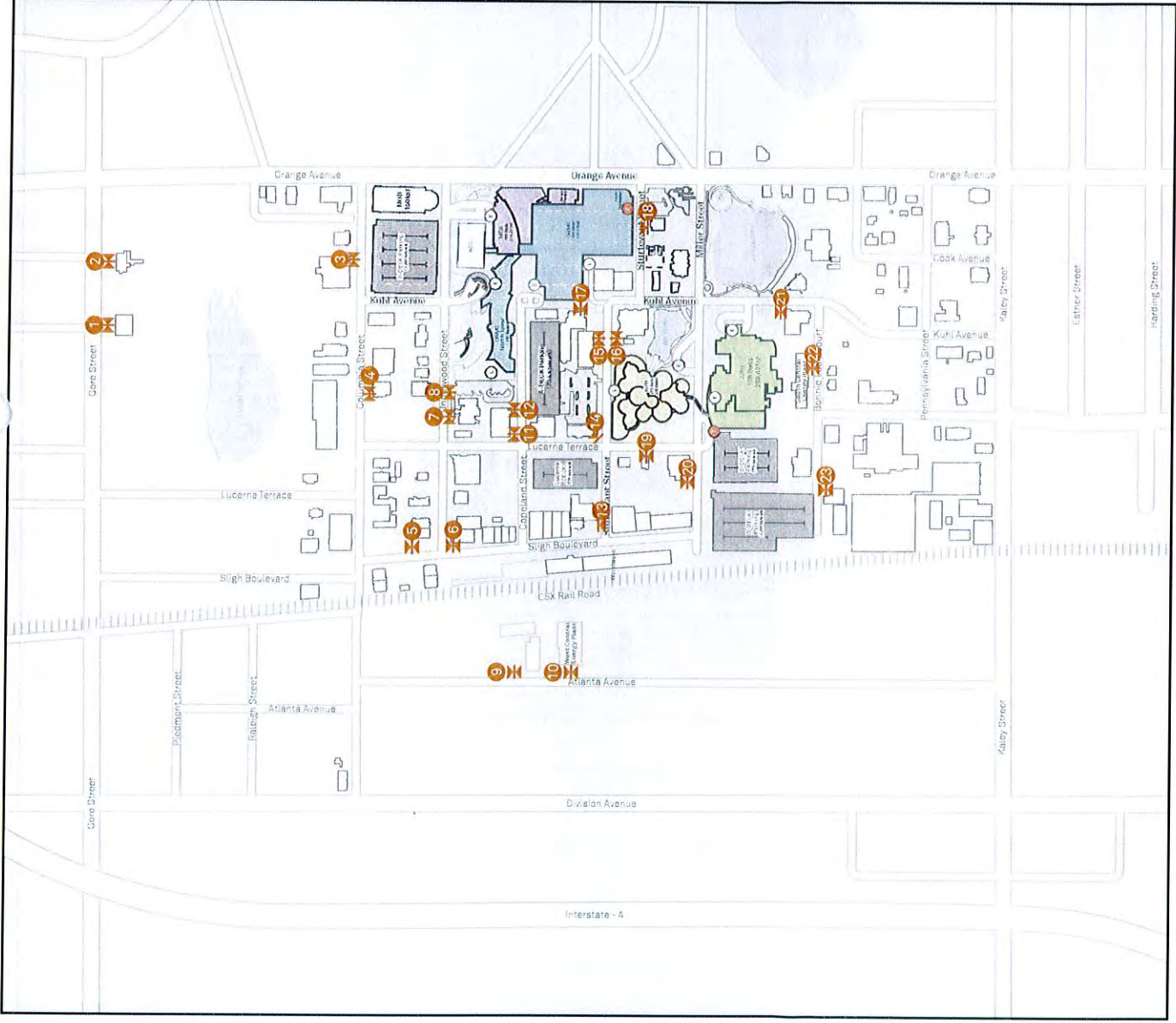

Legend	
	Arnold Palmer Hospital
	Winnie Palmer Hospital
	ORMC
	MD Anderson
	Hospital Entry
	Hospital Loading
	Emergency
	Building ID



Legend	
	Arnold Palmer Hospital
	Winnie Palmer Hospital
	ORMC
	MD Anderson
	Hospital Entry
	Hospital Loading
	Emergency
	Parking Directional
	Parking Garage ID

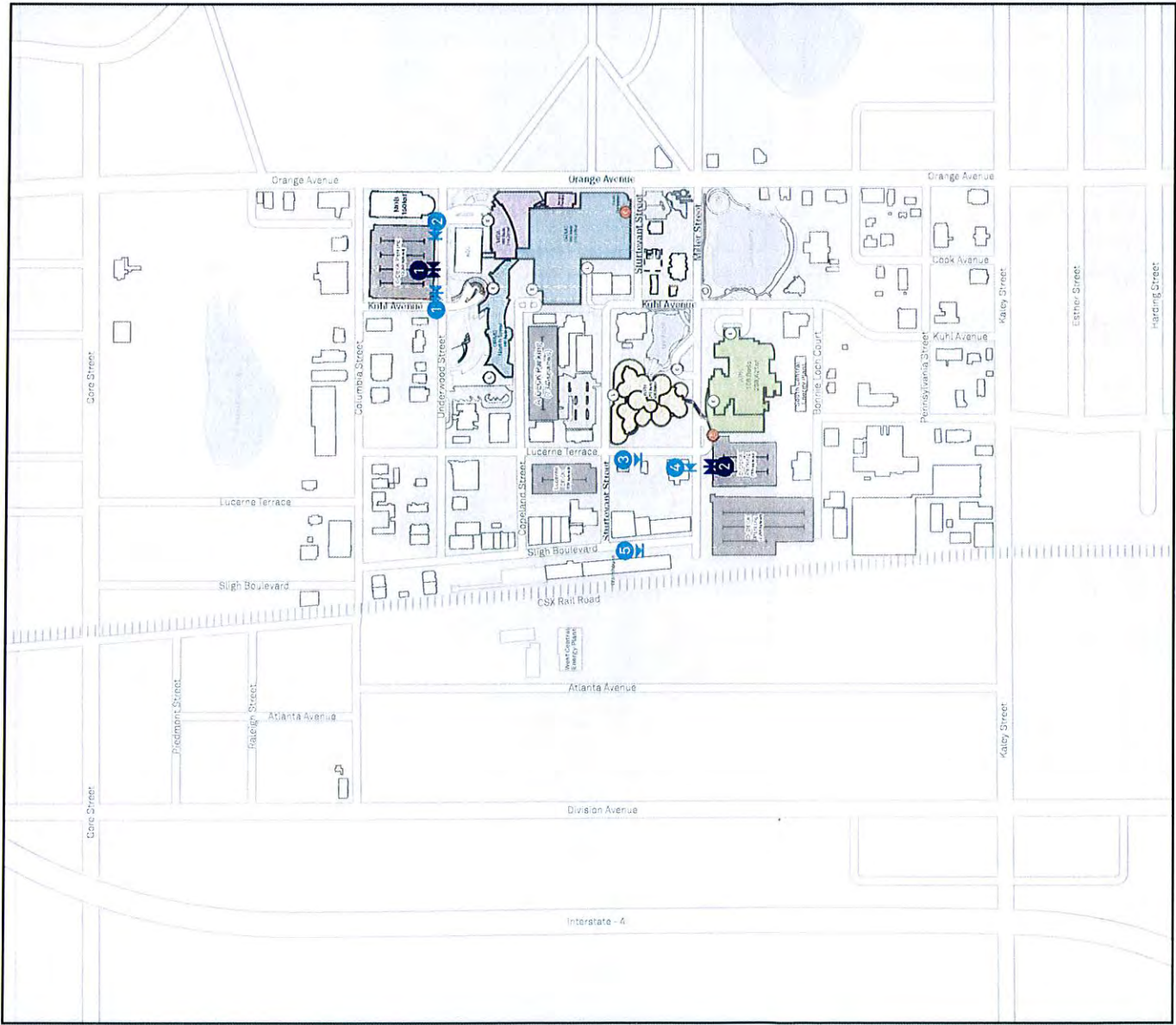

# Orlando Health PD Sign Plan Sign Location Plan — Parking

**Scale:** NTS

Note: Drawing scale shown on plans is accurate for full size plans only. AECOM is not responsible for scale discrepancies caused by reduced size plans.

**Description:**  
Sign Locations for Parking

**Original Issue Date:** 2012.04.25

**Contact:**  
Environmental Graphics/Wayfinding  
AECOM  
407-843-6552  
150 N Orange Avenue, Suite 200  
Orlando, Florida 32801





# Orlando Health PD Sign Plan Sign Location Plan — City of Orlando Vehicular Directional

Scale: NTS

Note: Drawing scale shown on plans is accurate for full size plans only. AECOM is not responsible for scale discrepancies caused by reduced size plans.

Description:  
Sign Locations for City of Orlando  
Vehicular Directional signs

Original Issue Date: 2012.04.25

Contact:  
Environmental Graphics/Wayfinding  
AECOM  
407-843-6552  
150 N Orange Avenue, Suite 200  
Orlando, Florida 32801

Prepared By:  
**AECOM**



Legend	
	Arnold Palmer Hospital
	Winnie Palmer Hospital
	ORMC
	MD Anderson
	Hospital Entry
	Hospital Loading
	Emergency
	City of Orlando Large Vehicular
	City of Orlando Small Vehicular



Legend	
	Arnold Palmer Hospital
	Winnie Palmer Hospital
	ORMC
	MD Anderson
	Hospital Entry
	Hospital Loading
	Emergency
	Vehicular Directional



# Orlando Health PD Sign Plan Sign Location Plan — Vehicular Directional

## Scale: NTS

Note: Drawing scale shown on plans is accurate for full size plans only. AECOM is not responsible for scale discrepancies caused by reduced size plans.

Description:  
Sign Locations for  
Vehicular Directional

Original Issue Date: 2012.04.25

Contact:  
Environmental Graphics/Wayfinding  
AECOM  
407-843-6552  
150 N Orange Avenue, Suite 200  
Orlando, Florida 32801

Prepared By:





Legend	
	Arnold Palmer Hospital
	Winnie Palmer Hospital
	ORMC
	MD Anderson
	Hospital Entry
	Hospital Loading
	Emergency
	Pedestrian Directional



# Orlando Health PD Sign Plan Sign Location Plan — Pedestrian Directional

**Scale:** NTS  
 Note: Drawing scale shown on plans is accurate for full size plans only. AECOM is not responsible for scale discrepancies caused by reduced size plans.

**Description:**  
 Sign Locations for Pedestrian Directional

**Original Issue Date:** 2012.04.25

**Contact:**  
 Environmental Graphics/Wayfinding  
 AECOM  
 407-843-6552  
 150 N Orange Avenue, Suite 200  
 Orlando, Florida 32801



Prepared By:  
**AECOM**



# Orlando Health PD Sign Plan

## Sign Location Plan — Pedestrian Kiosk Map

### Scale: NTS

Note: Drawing scale shown on plans is accurate for full size plans only. AECOM is not responsible for scale discrepancies caused by reduced size plans.

Description:  
Sign Locations for Pedestrian  
Directional

Original Issue Date: 2012.04.25

Contact:  
Environmental Graphics/Wayfinding  
AECOM  
407-843-6552  
150 N Orange Avenue, Suite 200  
Orlando, Florida 32801

Prepared By:

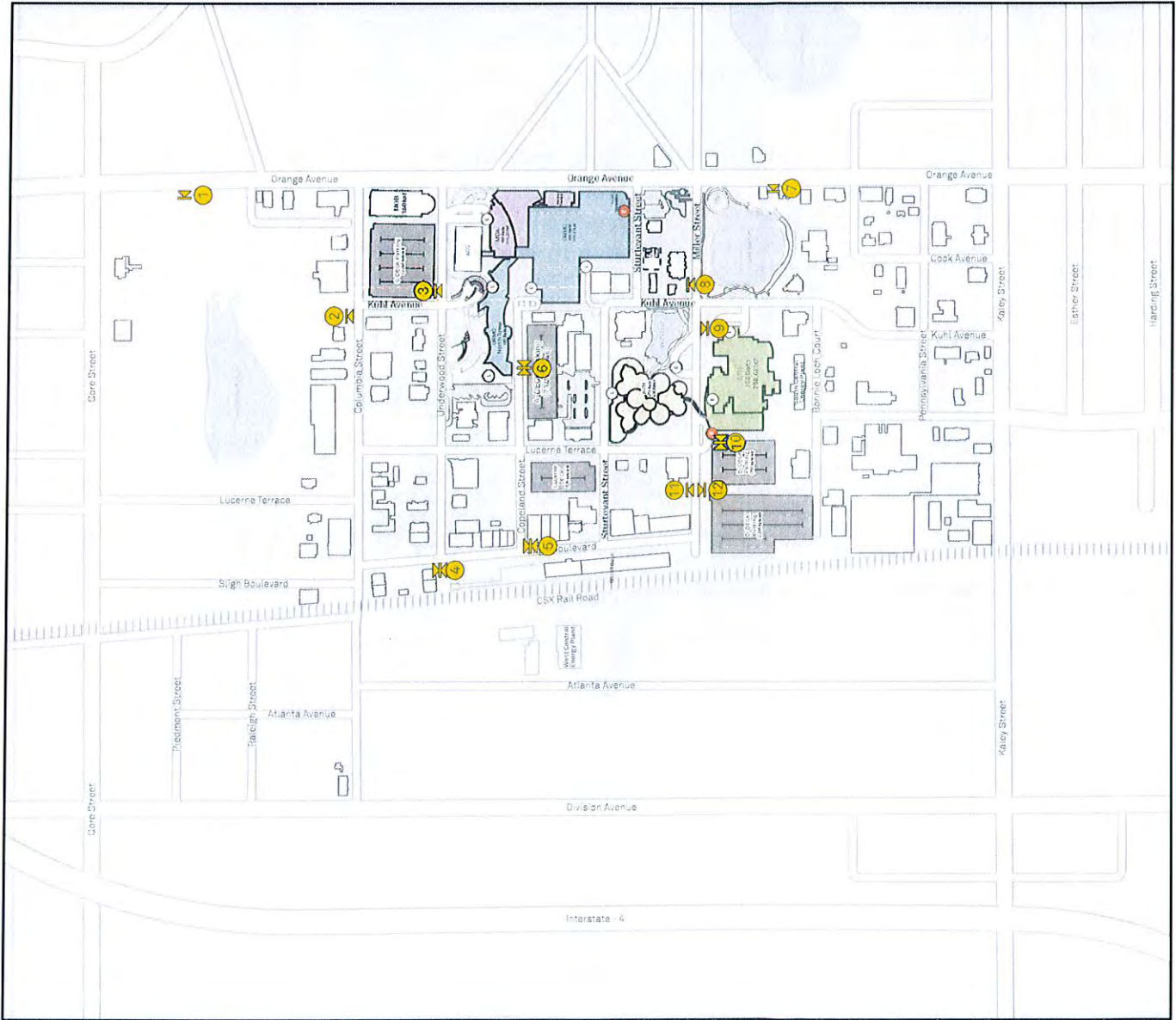

Legend	
	Arnold Palmer Hospital
	Winnie Palmer Hospital
	ORMC
	MD Anderson
	Hospital Entry
	Hospital Loading
	Emergency
	Pedestrian Kiosk Map



Legend	
	Arnold Palmer Hospital
	Winnie Palmer Hospital
	ORMC
	MD Anderson
	Hospital Entry
	Hospital Loading
	Emergency
	Sidewalk Medallions



# Orlando Health PD Sign Plan Sign Location Plan — Sidewalk Directional Medallions

## Scale: NTS

Note: Drawing scale shown on plans is accurate for full size plans only. AECOM is not responsible for scale discrepancies caused by reduced size plans.

Description:  
Sign Messages for  
Sidewalk Directional Medallions

Original Issue Date: 2012.04.25

Contact:  
Environmental Graphics/Wayfinding  
AECOM  
407-843-6552  
150 N Orange Avenue, Suite 200  
Orlando, Florida 32801

Prepared By:  
**AECOM**





Orlando Health  
PD Sign Plan  
Sign Location Plan —  
Sidewalk Directional  
Medallions

Scale: NTS

Note: Drawing scale shown on plans is accurate for full size plans only. AECOM is not responsible for scale discrepancies caused by reduced size plans.

Description:  
Sign Messages for  
Sidewalk Directional Medallions

Original Issue Date: 2012.04.25

Contact:  
Environmental Graphics/Wayfinding  
AECOM  
407-843-6552  
150 N Orange Avenue, Suite 200  
Orlando, Florida 32801

Prepared By:



10



11



12



# Orlando Health PD Sign Plan

## Sign Location Plan — Sidewalk Directional Medallions

Scale: NTS

Note: Drawing scale shown on plans is accurate for full size plans only. AECOM is not responsible for scale discrepancies caused by reduced size plans.

Description:  
Sign Messages for  
Sidewalk Directional Medallions

Original Issue Date: 2012.04.25

Contact:  
Environmental Graphics/Wayfinding  
AECOM  
407-843-6552  
150 N Orange Avenue, Suite 200  
Orlando, Florida 32801

Prepared By:



13



14



15



16



17



18





	<p>Orlando Health PD Sign Plan Sign Location Plan — Sidewalk Directional Medallions</p>	<p>Scale: NTS</p> <p>Note: Drawing scale shown on plans is accurate for full size plans only. AECOM is not responsible for scale discrepancies caused by reduced size plans.</p>	<p>Description: Sign Messages for Sidewalk Directional Medallions</p>	<p>Original Issue Date: 2012.04.25</p>	<p>Contact: Environmental Graphics/Wayfinding AECOM 407-843-6552 150 N Orange Avenue, Suite 200 Orlando, Florida 32801</p>		<p>Prepared By: <b>AECOM</b></p>
---	---	--	---	--	--	--	--------------------------------------



 <p><b>Orlando Health</b> PD Sign Plan</p>	<p><b>Sign Location Plan — Sidewalk Directional Medallions</b></p>	<p><b>Scale:</b> NTS</p> <p>Note: Drawing scale shown on plans is accurate for full size plans only. AECOM is not responsible for scale discrepancies caused by reduced size plans.</p>	<p><b>Description:</b> Sign Messages for Sidewalk Directional Medallions</p>	<p><b>Original Issue Date:</b> 2012.04.25</p>	<p><b>Contact:</b> Environmental Graphics/Wayfinding AECOM 407-843-6552 150 N Orange Avenue, Suite 200 Orlando, Florida 32801</p>	<p>Prepared By: <b>AECOM</b></p>
--	--	---	--	---	---	--------------------------------------

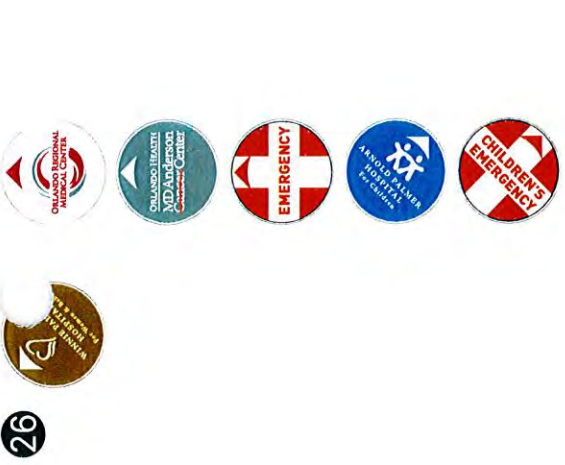



## **Documentation of Other Approved Signs**

The following photos document previously approved signs that do not conform to the adopted sign plan palette. Each of these signs is unique due to their location, construction, or use of individual logos or building names.

### ***High Rise Signs***

High rise signs are governed by the OH PD and the Section 64.246 of the City of Orlando code. They are labeled HRI on the High Rise Sign Map.

### ***Wall-Mounted Signs***

Unique wall-mounted signs are labeled as WBI signs on the Other Campus Signs Map. These signs are used at key campus buildings such as ORMC and MD Anderson where specialized signage and identification is warranted and where ground-mounted ID signs are not feasible.

### ***Other Identification Signs***

Unique ground-mounted signs are labeled OI on the Other Campus Sign map. Efforts have been made to reduce existing OI signs and prevent the proliferation of such individual ground signs. Thus far, these have been reduced to a total of three signs.



# Orlando Health PD Sign Plan Master Signage Plan High Rise Signs

## Scale: NTS

Note: Drawing scale shown on plans is accurate for full size plans only. AECOM is not responsible for scale discrepancies caused by reduced size plans.

Description:  
High Rise Signs

Original Issue Date: 2012.06.15

Contact:  
Environmental Graphics/Wayfinding  
AECOM  
407-843-6552  
150 N Orange Avenue, Suite 200  
Orlando, Florida 32801

Prepared By:



Legend	
	Arnold Palmer Hospital
	Winnic Palmer Hospital
	ORMC
	MD Anderson
	Hospital Entry
	Hospital Loading
	Emergency
	Wall-Mounted Building Identification
	High Rise Identification
	Other Identification
	Block Number





# Orlando Health PD Sign Plan Master Signage Plan Identification Signs

## Scale: NTS

Note: Drawing scale shown on plans is accurate for full size plans only. AECOM is not responsible for scale discrepancies caused by reduced size plans.

## Description: Identification Signs

Original Issue Date: 2012.06.15

Contact:  
Environmental Graphics/Wayfinding  
AECOM  
407-843-6552  
150 N Orange Avenue, Suite 200  
Orlando, Florida 32801

Prepared By:

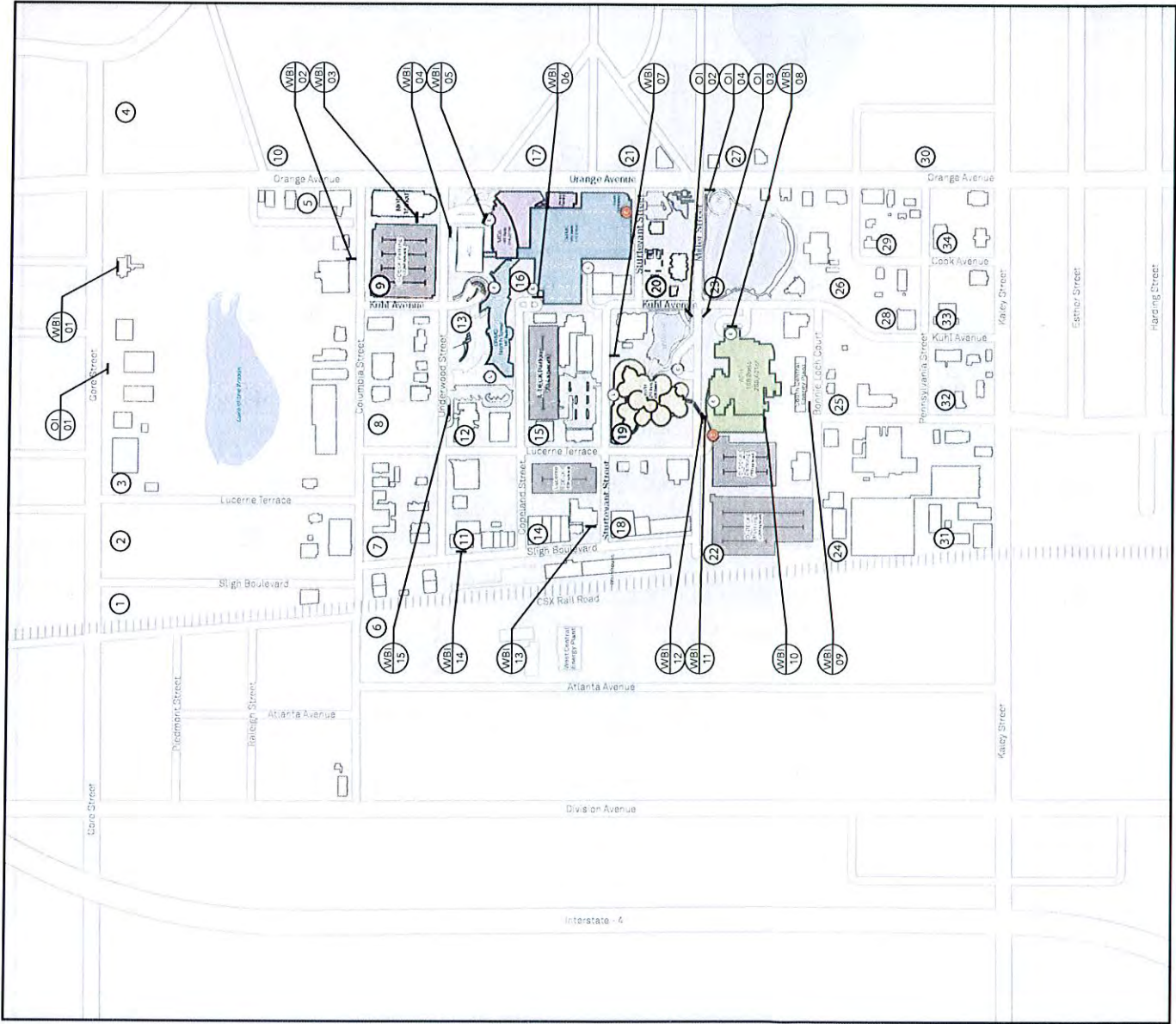

Legend		Sign Type	Sign Number
	Arnold Palmer Hospital		01
	Winnie Palmer Hospital		
	ORMC		
	MD Anderson		
	Hospital Entry		
	Hospital Loading		
	Emergency		
	Wall-Mounted Building Identification		
	High Rise Identification		
	Other Identification		
	Block Number		



OI-01

Facing east or west from Gore St. (identical faces).



OI-02

Facing southwest from Miller St.

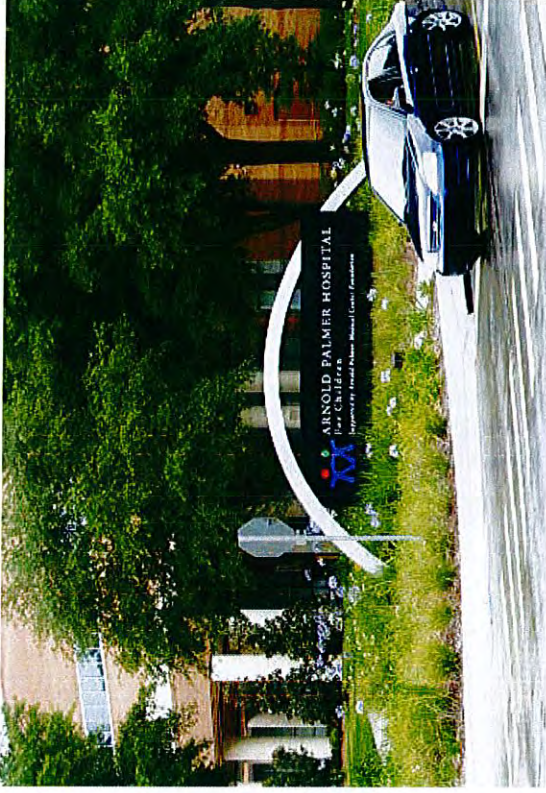

Close-up





OI-03

Facing northwest from Miller St.



WBI-01

Facing south from Gore St.



WBI-02

Facing north from Underwood St.



Close-up

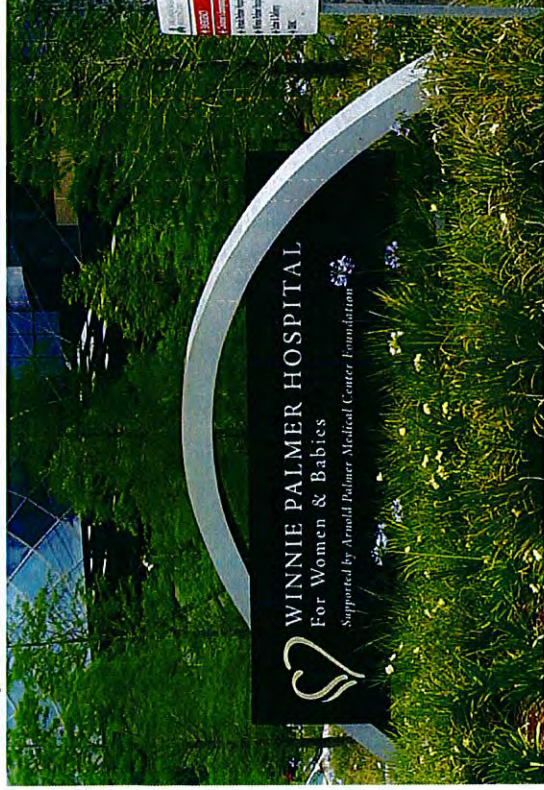



WBI-03

Facing south from Underwood St.



WBI-04

Facing south from Underwood St.



Close-up



Close-up





WBI-05

Facing east from Copeland St.



Close-up



WBI-06

Facing west from Kuhl Ave.



Close-up





WBI-07

Facing north from Bonnie Loch Ct.



WBI-08

Facing north from Bonnie Loch Ct.



Close-up



Close-up

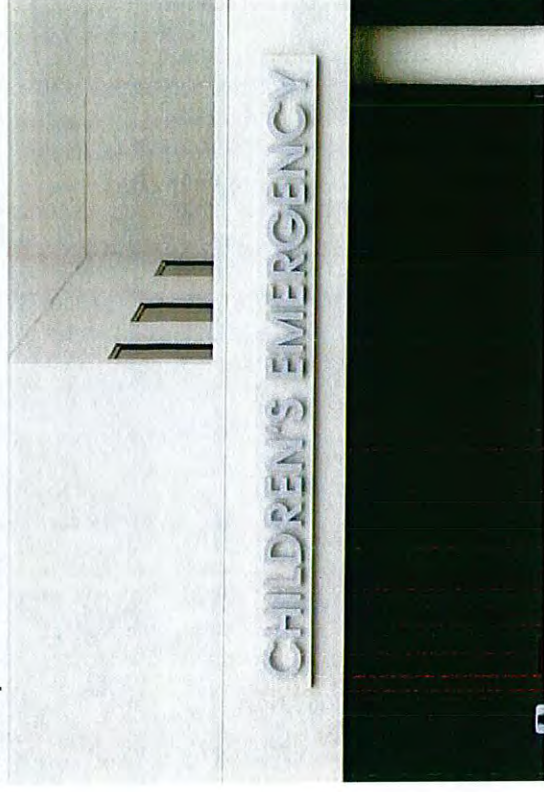



WBI-09

Facing south from Miller St.



Close-up



WBI-10

Facing south from Miller St.



Close-up





WBI-11

Facing east from Sligh Blvd.



WBI-12

Facing east from Sligh Blvd.

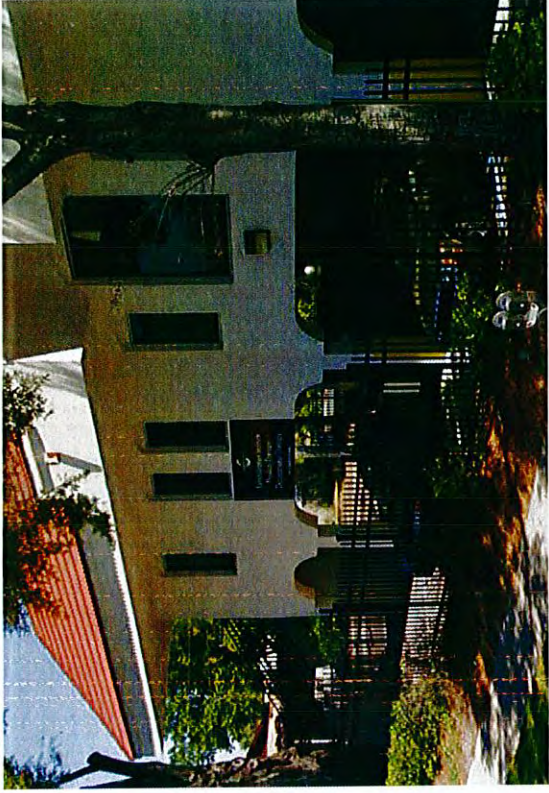

Close-up





WBI-13

Facing south from Underwood St.

